

# VK-OA™ Vertical Outside-Air A/C's



**2 to 30 Tons**

***"Vertical Floor Mounted A/C's"***

***Vertical Floor Mounted  
(DX & CW Systems)***

## Features & Benefits

- 300 to 10,000 CFM / 2 to 30 Tons
- *Outside Air Application*
  - 95°F DB / 78°F WB EAT
  - 55°F DB / 54°F WB LAT Off Coil
  - Hot Gas Reheat to Space Neutral
  - Precision Space Control via SCR Electric, Proportional Hot Water, Steam or Direct Gas-Fired Reheat
- *Typical Applications*
  - General Office Spaces
  - Conference Rooms
  - Restaurants / Retail Stores
  - Computer / Server Rooms
  - Morgues
  - Labs / Hospitals
- Vertical Floor Mounted, Packaged & Split Systems
- DX Air, Water & Glycol Cooled, Chilled Water & Free-Cooling
- Microprocessor Dew PT Control



**MEA229-06-E**

**AboveAir™** VertiKUL™ SCAV vertical floor mounted air conditioners are the reliable solution to your comfort cooling control needs. Available in a wide variety of cooling methods and cabinet configurations including a full range of options, **AboveAir™** A/C's are a step above!



- ☑ R407c or Optional R410a Refrigerant
- ☑ Modular For Rigging Purposes
- ☑ Packaged & Split Systems
- ☑ Top or Front Evap Air Discharge
- ☑ Variety of cooling methods
- ☑ Air Side and Water-Glycol Economizers
- ☑ VAV / VFD Application Option
- ☑ Flexible options and accessories
- ☑ Energy efficient operation

## Model Nomenclature

### Packaged Systems & Split Evaporators

**V K W - 1 2 0 - 4 - OA**  
a b c d e

- a: **VK** - VertiKUL™ Series
- b: **A** - DX, Air Cooled Self-Contained  
**C** - Chilled Water  
**E** - DX, Air Cooled Evaporator  
**H** - DX, Air Handling Unit  
**W** - DX, Water Cooled  
**G** - DX, Glycol Cooled
- c: Nominal Cooling Capacity in MBH
- d: **1** - 208-230/1/60  
**3** - 208-230/3/60  
**4** - 460-480/3/60  
**5** - 575-600/3/60  
**7** - 277/1/60 via step down-transformer
- f: **DC** - Dual-Cool (Alternate Water Source) System  
**HP** - Heat Pump Configuration  
**FE** - Free-Cooling Economizer System  
**OA** - 100% Outside-Air Option Package

### Remote Heat Rejection

**X P 2 - 1 8 0 - 4**  
a b c d e

- a: **X** - Heat Exchanger  
**F** - FluidCool Remote Glycol Drycooler
- b: **C** - DX, Air Cooled, Horizontal Mtd, Centrifugal Blower Type  
**P** - DX, Air Cooled, Propeller Fan Type  
**V** - DX, Air Cooled, Vertical Floor Mtd, Centrifugal Blower Type
- c: **1** - Single Circuit DX Air Cooled Remote Condenser  
**2** - Dual Circuit DX Air Cooled Remote Condenser  
**U** - Condensing Unit
- d: Nominal Cooling Capacity or Total Heat of Rejection in MBH
- e: **1** - 208-230/1/60  
**3** - 208-230/3/60  
**4** - 460-480/3/60  
**5** - 575-600/3/60  
**7** - 277/1/60 via step down-transformer

## Contents

<b>Introduction</b> .....	2
<b>Model Nomenclature</b> .....	2
<b>Features and Benefits</b> .....	3
<b>Performance Data</b> .....	3
<b>Unit Dimensional Data</b> .....	4-6
<b>Guide Specifications</b> .....	7-10

## Nominal Performance Data (LAT = 55°F DB / 54°F WB Off Cooling Coil)

HK™ Horizontal / VK™ Vertical Model	100% OA Outside-Air		60% Outside-Air		40% Outside-Air		20% Outside-Air	
	95°F DB / 78.0°F WB Mixed EAT		87.0°F DB / 71.8°F WB Mixed EAT		83.0°F DB / 68.7°F WB Mixed EAT		79.0°F DB / 65.6°F WB Mixed EAT	
	Total Evap Airflow Rate	Nom. Cooling Capacity	Total Evap Airflow Rate	Nom. Cooling Capacity	Total Evap Airflow Rate	Nom. Cooling Capacity	Total Evap Airflow Rate	Nom. Cooling Capacity
	CFM	TMBH / SMBH	CFM	TMBH / SMBH	CFM	TMBH / SMBH	CFM	TMBH / SMBH
A_C / VK_-036_-OA	435	36.3 / 18.9	630	36.1 / 21.9	790	36.0 / 24.0	1,040	36.1 / 27.1
A_C / VK_-048_-OA	575	48.0 / 25.0	840	48.1 / 29.2	1,055	48.1 / 32.1	1,385	48.0 / 36.1
A_C / VK_-060_-OA	720	60.1 / 31.3	1,050	60.2 / 36.5	1,315	60.0 / 40.0	1,730	60.0 / 45.1
A_C / VK_-072_-OA	865	72.2 / 37.6	1,260	72.2 / 43.8	1,580	72.1 / 48.1	2,080	72.1 / 54.3
A_C / VK_-090_-OA	1,080	90.2 / 47.0	1,570	90.0 / 54.6	1,975	90.1 / 60.1	2,600	90.1 / 67.8
A_C / VK_-096_-OA	1,150	96.0 / 50.0	1,675	96.0 / 58.3	2,100	95.8 / 63.9	2,770	96.0 / 72.3
A_C / VK_-120_-OA	1,440	120.2 / 62.6	2,100	120.4 / 73.0	2,630	120.0 / 80.0	3,460	119.9 / 90.3
A_C / VK_-144_-OA	1,725	144.0 / 75.0	2,515	144.1 / 87.5	2,160	98.5 / 65.7	4,155	144.0 / 108.4
A_C / VK_-180_-OA	2,160	180.3 / 93.9	3,140	180.0 / 109.2	3,950	180.2 / 120.2	5,195	180.1 / 135.5
A_C / VK_-199_-OA	2,390	199.5 / 103.9	3,475	199.2 / 120.9	4,370	199.3 / 133.0	5,750 *	199.3 / 150.0
A_C / VK_-216_-OA	2,675	223.3 / 116.3	3,895	223.2 / 135.5	4,895	223.3 / 149.0	6,440 *	223.2 / 168.0
A_C / VK_-240_-OA	2,875	240.0 / 125.0	4,190	240.2 / 145.7	5,262	240.0 / 160.2	6,925 *	240.1 / 180.7
A_C / VK_-300_-OA	3,600	300.5 / 156.5	5,235	300.0 / 182.1	6,580 *	300.1 / 200.3	8,655 *	300.0 / 225.8
A_C / VK_-360_-OA	4,315	360.2 / 187.6	6,280 *	359.9 / 218.4	7,895 *	360.1 / 240.3	10,385 *	360.0 / 270.9

**Notes:** 1) Data based on 95°F DB / 78°F WB Summer Outside-Air Temperature and 75°F DB / 62.5°F Space Temperature.  
2) \* - Available in VK Vertical model sizes only.



### Standard Features:

- MC-3000, Advanced Dew Pt Outside-Air Microprocessors w/ Alarms & BMS Options
- Multi-Row Deep Cooling Coils
- Modulating Hot Gas Reheat to 75°F LAT
- Scroll Compressors
- Modulating Flooded Head Pressure Control
- Hot Gas Bypass
- Suction-Line Accumulators
- 1" Closed-Cell Insulated Cooling Sections
- Adjustable Belt-Drive DWDI Blowers
- High Efficiency Air Filtration

### Optional Features:

- Electric SCR Fired, Hot Water or Steam Pre &/or Post Heat
- Condensate Pumps
- Main Power Electrical Disconnects
- Firestats & Smoke Detectors
- Remote Water-Leak Detectors
- Compressor Sound Jackets
- Glycol Pump Packages & Drycoolers
- ... and more!



MEA229-06-E Approved

**“Cabinet-A”:** DX - Water/Glycol & Split Air Cooled Evaporators

Models: VKW, VKG, VKE & VKH-024, 030, 036, 048, 060 & 072-\_-OA  
 (Vertical, 2 to 6 Tons (up to 2500 CFM), Single Compressor Outside Air A/C’s)

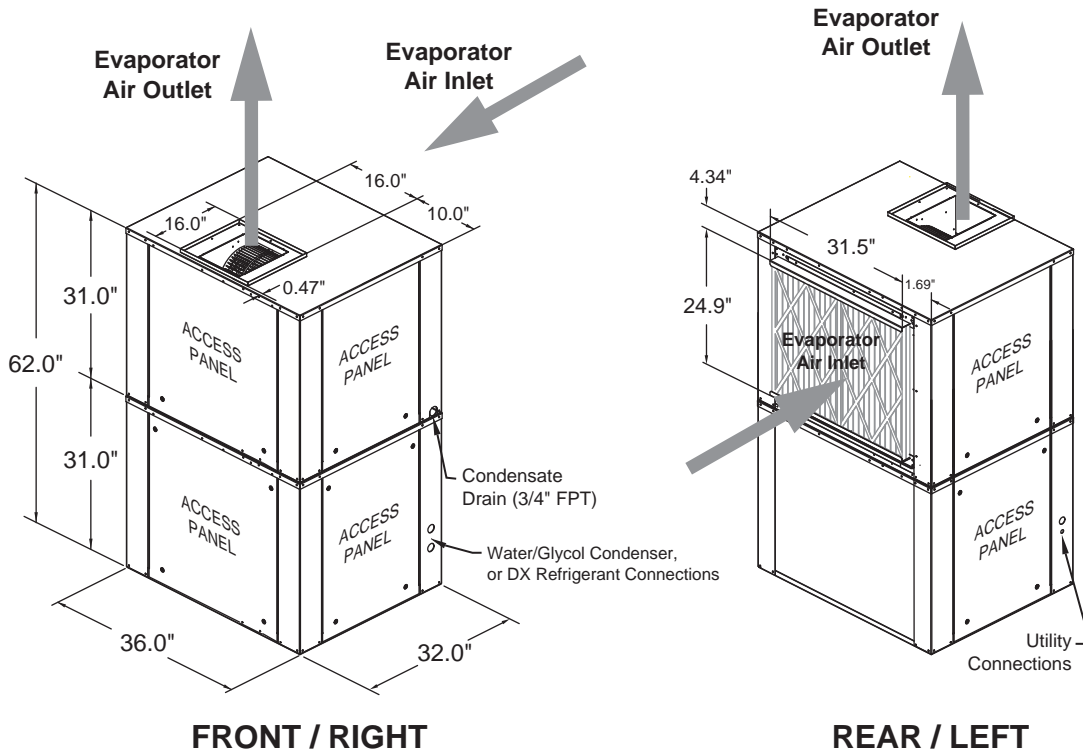

**“Cabinet-B”:** DX - Water/Glycol & Split Air Cooled Evaporators

Models: VKW, VKG, VKE & VKH-096, 120, 144, 180, 199, 240 & 300-\_-OA  
 (Vertical, 8 to 25 Tons (up to 4920 CFM), Dual Compressor Outside Air A/C’s)

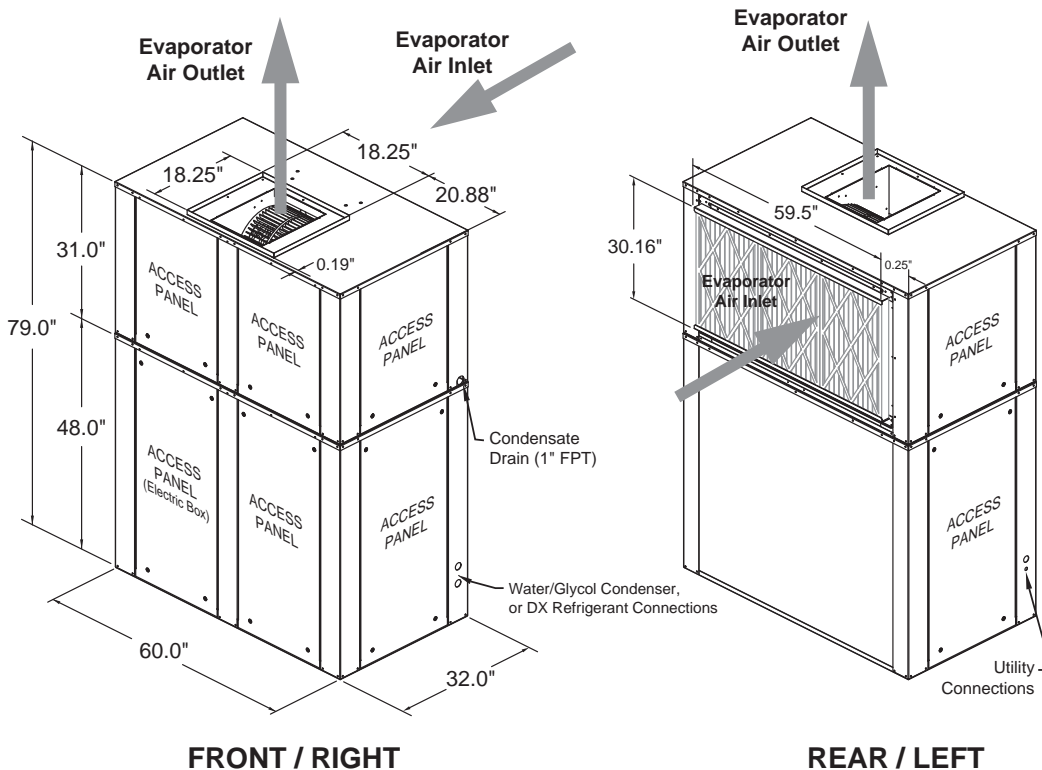

**“Cabinet-C”: DX - Water/Glycol & Split Air Cooled Evaporators**

Models: VKW, VKG, VKE & VKH-180, 199, 240, 300 & 360-\_-OA  
 (Vertical, 15 to 30 Tons (up to 8100 CFM), Dual Compressor Outside Air A/C's)

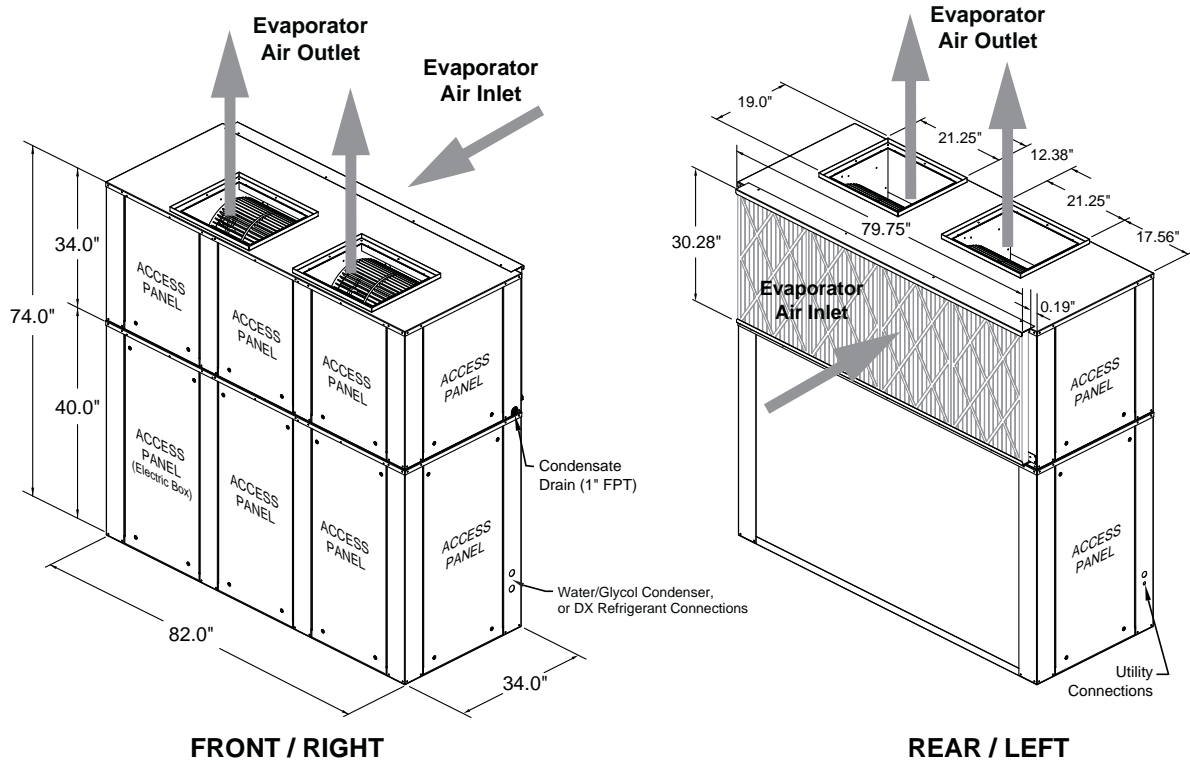

**“Cabinet-D”: DX - Water/Glycol & Split Air Cooled Evaporators**

Models: VKW, VKG, VKE & VKH-240, 300 & 360-\_-OA  
 (Vertical, 20 to 30 Tons (up to 10,000 CFM), Dual Compressor Outside Air A/C's)

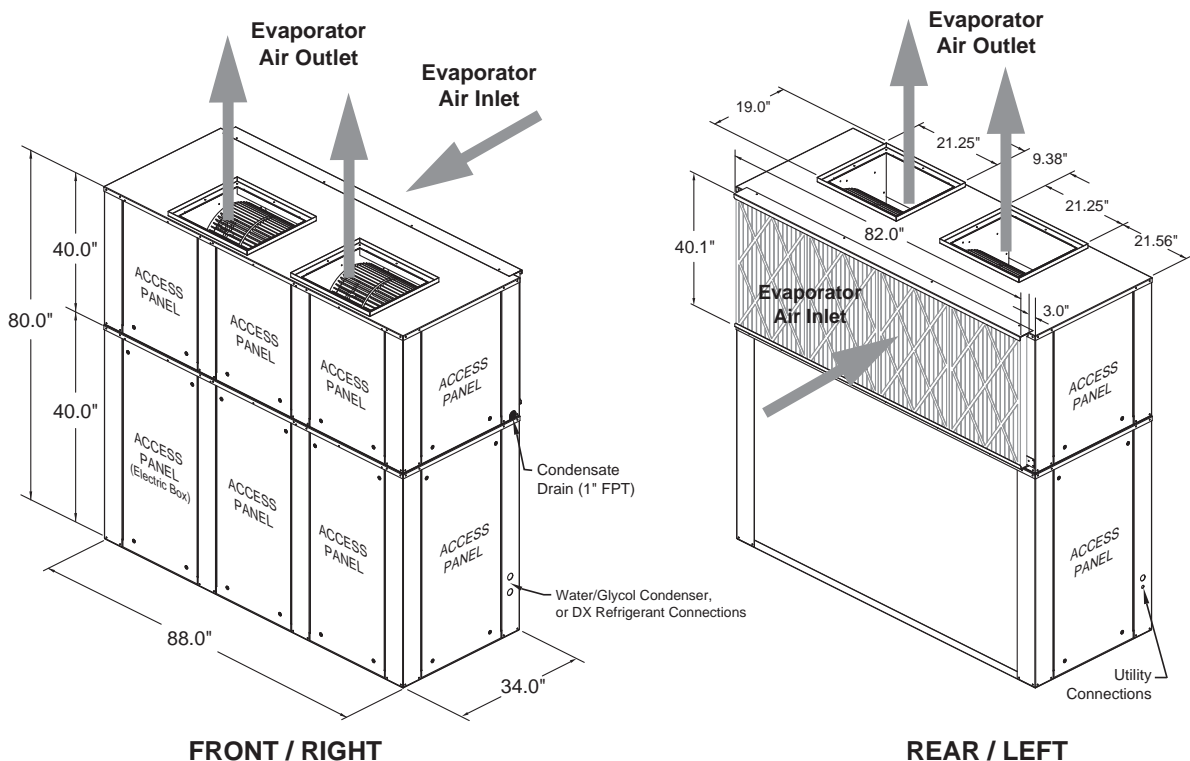

## Remote Outdoor Propeller Fan Air Cooled Condensers

### XP1-036 & 060

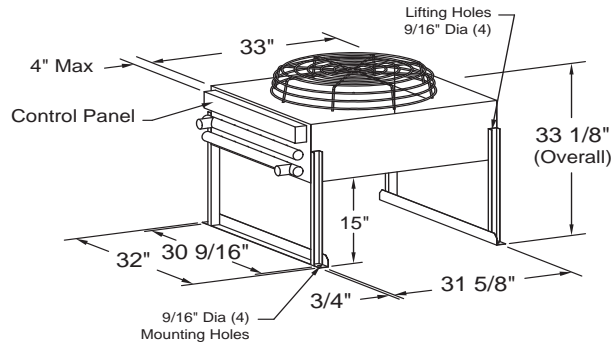

### XP1/XP2-096,-120 & 144

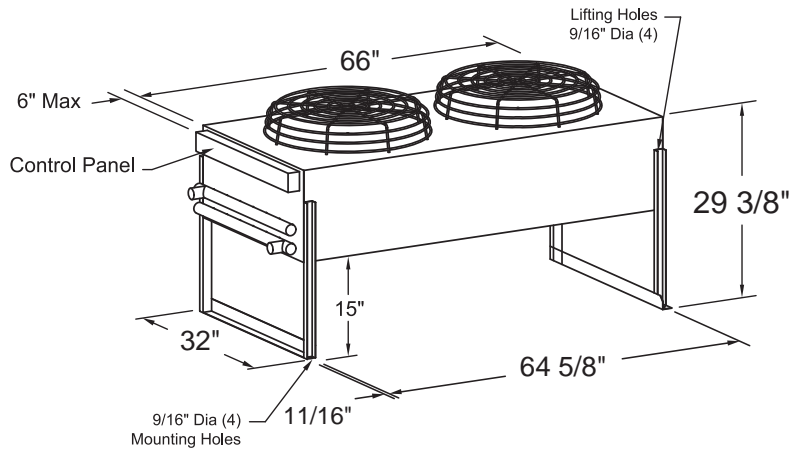

### XP2-180, 192, 240, 264, 300, 336, 372 & 432

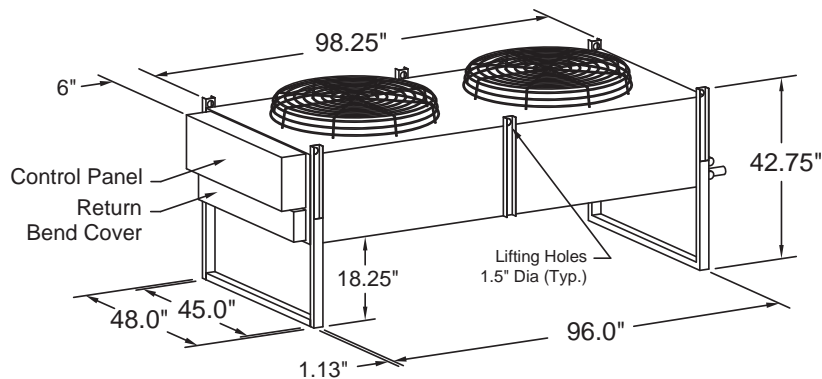

## 1.0 General

### ☑ 1.1 Summary



These specifications describe the requirements for a 0 to 100% Outside Air horizontal ceiling mounted air conditioner.

These specifications describe the requirements for an Outside Air vertical floor mounted packaged (or split) air conditioner.

The air conditioning manufacturer shall design and furnish all equipment in the quantities and configurations shown on the project plans and specifications.

The system shall be provided by AboveAir Technologies in Frederick, Maryland, USA. The system shall be approved and labeled as such by Intertek (ETL) to comply with UL 1995. The system shall be New York City MEA229-06-E and Chicago Code Approved. The system model number shall be \_\_\_\_\_.

### ☑ 1.2 Design Requirements

The system shall be an AboveAir Technologies VK-OA™ brand factory assembled and tested. The system shall be designed for indoor installation.

The system shall have a total cooling capacity of \_\_\_\_\_ BTU/H, and a sensible cooling capacity of \_\_\_\_\_ BTU/H, based on an entering air condition of \_\_\_\_\_ °F DB, and \_\_\_\_\_ °F WB, \_\_\_\_\_ % RH.

The evaporator section shall be designed for \_\_\_\_\_ Volt, \_\_\_\_\_ Phase, \_\_\_\_\_ Hertz main power supply. The remote condensing unit section (if applicable) shall be designed for \_\_\_\_\_ Volt, \_\_\_\_\_ Phase, \_\_\_\_\_ Hertz main power supply.

### ☑ 1.3 Submittals

Submittals shall be provided after manufacturer's receipt of a written purchase order and shall include: Detailed Performance and Electrical Data; Guide Specifications; and Dimensional Drawings.

### ☑ 1.4 Quality Assurance

The system shall be factory run tested prior to shipment. Testing shall include, but shall not be limited to: "HiPot" Test (2 times rated voltage plus 1000 volts, per UL 1995 testing requirements). The system shall be designed and manufactured according to world class quality standards.

## 2.0 Products

### ☑ 2.1 Standard Features / All Systems

#### ☑ 2.1.1 Cabinet (1" Armaflex Lined Evap)

The cabinet chassis and access panels shall be powder-coat painted heavy gauge galvalneal steel for decor matching and corrosion resistance. Cabinet access panels shall rest in recessed pockets designed for minimum air leakage. The cabinet and access panels shall be lined with a 1" closed-cell neoprene 2 lb/ft<sup>2</sup> high density sound and thermal insulation and sealed with self-extinguishing gasketing conforming to NFPA 90A and 90B.

#### ☑ 2.1.2 Service Access

The unit shall be designed for ease of service access thru front & side access panels with quick-release quarter-turn fasteners.

#### ☑ 2.1.3 Electrical System

##### General:

The electrical system shall conform to National Electric Code (NEC) requirements according to UL 1995. The control circuit shall be a 24 VAC low voltage circuit.

The electrical system shall include, but not be limited to the following factory installed items: main power distribution block; grounding lug; 24 VAC control transformer; terminal connections; and motor controllers with start protection and circuit breakers for blower motors, compressors and each electric heater stage (if applicable).

**Packaged Systems:** (single point power) Self-Contained systems shall be designed for single point main power connection.

**Split DX Systems:** (separate power) Split systems shall require separate main power supplies to the evaporator

and condensing unit sections. The evaporator and condensing unit sections shall be electrically interlocked by a field wired 24 volt control signal.

#### Overflow Safety Float Switches:

The system shall be provided with a factory installed float type condensate overflow safety switches. The circuit shall be designed to shut down all system water producing operations in the event of a overflow condition.

### ☑ 2.1.4 Air Distribution



The system air distribution shall be configured for a draw-through air pattern to provide even air distribution and maximum coil performance.

#### ☑ 2.1.4.1 Blowers / Motors

The blower shall be the belt-driven centrifugal type, double width double inlet (DWDI), and statically and dynamically balanced to a minimum vibration level. The shaft shall be heavy duty steel with self-aligning ball bearings sized for an average 100,000 hours of service life.

The blower motor shall be \_\_\_\_\_ Hp at 1725 RPM (or 3450 RPM) and mounted on an adjustable base. Belts shall be sized for 200% of the motor horsepower rating. Motors shall have overload protection and a minimum NEMA service factor of 1.15.

#### Evaporator Blowers:

The evaporator blower assembly shall be designed for \_\_\_\_\_ CFM @ \_\_\_\_\_ inches external static pressure (e.s.p.)

#### ☑ 2.1.4.2 Air Patterns

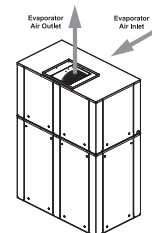

Top Discharge (standard)

#### Top Evap Air Discharge: (standard)

The evaporator shall be designed for free or ducted rear-unit return air inlet and top

ducted air discharge. Air inlet and outlet connections shall include factory provided turned-out duct flanges for each of field duct connection.

### ☑ 2.1.4.3 Air Filtration

The filter(s) shall be 4 inch thick pleated and rated for 30% dust spot efficiency (based on ASHRAE 52.1). The filter(s) shall be serviceable through a side access without shutting down the system.

## ☑ 2.2 Direct Expansion Systems

### ☑ 2.2.1 DX - Evaporator Coils



The DX evaporator coil shall be specifically designed for the deep and wide range cooling requirements of 100% outside-air A/C applications. The coil shall be constructed of copper tubes and aluminum fins. The system shall be designed for a draw-through air pattern for maximum heat transfer. Coil end-plates shall be hot dipped galvanized. The evaporator coil shall be mounted in an insulated stainless steel condensate drain pan.

### ☑ 2.2.2 Scroll Compressors



Each compressor shall be the high efficiency, low sound Scroll type mounted on vibration isolators and located in a separate compartment out of the evaporator air stream to facilitate servicing while equipment is operating. Each compressor shall be complete with reversible positive oil pump, charging and service ports, internal spring isolation, and discharge gas vibration eliminator.

### ☑ 2.2.3 DX - Refrigeration Circuits



Each refrigeration circuit shall be pre-piped with type "L" refrigerant copper tubing. The refrigeration system shall include but not be limited to: expansion valve with external equalizer and rapid bleed-through capacity. Features shall include filter dryer, sight glass, pressure fittings and high pressure/low pressure safety cutouts.

### ☑ 2.2.4 Hot Gas Bypass

#### ☐ 2.2.4.1 Hot Gas Bypass To Evap Coil Inlet (Compressor located in Evap)



Each refrigerant circuit shall include a factory installed Hot gas bypass system to provide evaporator coil freeze-protection and capacity modulation control under low load conditions.

#### ☐ 2.2.4.2 Hot Gas Bypass To Suction Line with Quench Valve (Compressor Located in Remote Condensing Unit - 3<sup>rd</sup> Line Not Required!)



Each refrigerant circuit of the Split DX system shall be provided with a factory installed hot gas bypass system to include: hot gas (discharge) bypass; desuperheating quench; and hot gas & quench solenoid valves. The hot gas bypass system shall be designed to supply hot gas and liquid refrigerant to the suction line as required to provide coil freeze-protection and capacity modulation under low load conditions. All hot gas bypass components shall be factory installed and shall not require additional field refrigerant lines on split DX systems.

### ☑ 2.2.5 Suction-Line Accumulator



Each refrigerant circuit shall be provided with a factory installed Suction-Line Accumulator to prevent liquid slugging of the compressor and excessive refrigerant dilution of the compressor oil during low load conditions. The accumulator shall return refrigerant and oil to the compressor at a sufficient rate to maintain both system operating efficiency and proper oil level. The accumulators shall be wrapped with a 1/2" closed-cell neoprene insulation to prevent sweating.

### ☐ 2.2.6 Modulating Flooded Head Pressure Control

A flooded condenser system shall be provided to modulating head pressure control as required. Each refrigerant circuit of the flooded system shall include a factory installed liquid refrigerant receiver, 3-way modulating head pressure control valve and compressor crankcase heater.

### ☐ 2.2.7 Modulating Variable Spd Fan Head Pressure Control (Propeller Fan Condensers)

Modulating Variable fan speed head pressure controls shall be factory installed within the propeller fan condenser. Each refrigerant circuit shall be included factory installed liquid refrigerant receiver, compressor cold start time delay relay and crankcase heater

## 2.3 Standard Features / Individual Systems

### ☐ 2.3.1 DX - Air Cooled (Split Evaporator Systems) Models: VKE(-)-OA

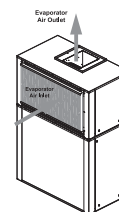

The system shall be a split dx, vertical floor mounted evaporator section for connection to a remote air cooled condenser. The compressor(s) shall be

located in the evaporator section. The evaporator shall include, but not be limited to: evaporator coil; centrifugal belt-driven blower and blower motor; thermal expansion valve with rapid bleed port, shraeder service valves; compressor(s), refrigerant filter-drier and sight-glass; main power distribution block; grounding lug; 24 Vac control transformer; individual blower motor contactors; and terminal strip.

The system shall require only single point main power supply and ship from the factory with a dry-nitrogen holding charge for field sweat (copper) connection and refrigerant charging.

**2.3.1.2 DX - Air Cooled Remote Condensing Unit**  
(Outdoor Propeller Fan)  
XP\_(-)



The system shall be an outdoor mounted remote air cooled direct-driven propeller fan(s) condenser. The remote condensing unit shall include, but not be limited to: condenser coil; direct drive propeller fan(s) and fan motor(s); close-meshed steel wire with vinyl coating fan guards; shraeder service valves; main power distribution block; grounding lug; dry-contact interlock for evaporator 24 Vac control signal; fan motor starters/contactors; and terminal strip.

The condenser shall be sized for full heat of rejection at 95°F ambient and be capable of operation to \_\_\_ °F low ambient air temperature.

The condenser shall ship from the factory with a dry-nitrogen holding charge for field sweat (copper) connection.

**2.3.2 DX - Water Cooled**

**2.3.2.1 DX - Water Cooled (Self-Contained Systems)**  
Models: VKW(-)-OA

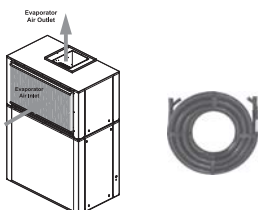

The system shall be a self-contained, vertical floor mounted air conditioner with integral dx water cooled condensing

unit. The system shall include a water cooled tube-in-tube coaxial condenser and factory installed flooded head pressure receiver including liquid refrigerant receiver and modulating head pressure control valve. The water cooled condenser shall be designed to provide the total required system heat of rejection at 85°F entering water temperature and 95°F leaving water temperature. Source water shall be provided by a remote water source (*by others*).

The system shall require only single point main power supply and ship from the factory with a full operating refrigerant charge.

**2.3.3 DX - Glycol Cooled**

**2.3.3.1 DX - Glycol Cooled (Self-Contained Systems)**  
VKG(-)-OA

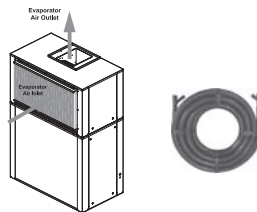

The system shall be a self-contained, vertical floor mounted air conditioner with integral dx glycol cooled condensing unit. The system shall include a glycol cooled tube-in-tube coaxial condenser and factory installed flooded head pressure receiver including liquid refrigerant receiver and modulating head pressure control valve. The condenser shall be designed to provide the total required system heat of rejection at 110°F entering glycol temperature and 120°F leaving glycol temperature based on 40% ethylene glycol solution. Source glycol shall be provided by a remote glycol drycooler source (*see AboveAir Technologies' FluidCool™ drycoolers*).

The system shall require only single point main power supply and ship from the factory with a full operating refrigerant charge.

**2.3.3.2 Glycol Pump Packages & Drycoolers**  
FC\_(-)/PA(-)



Glycol condenser source shall be provided by a FluidCool™ brand remote air cooled glycol drycooler and Pump-

All™ brand pump package.

The glycol drycooler shall be the outdoor mounted propeller fan type complete with factory installed aquastat fan cycling controls, motor starters with overload protection and non-fused disconnect switch.

The glycol pump package shall be a (single or dual) pump package designed for outdoor installation complete with individual pump motor starters. Dual glycol pump packages shall be provided with manual lead-lag switch and field installed flow switch for automatic switchover to backup pump upon loss of flow.

An expansion tank and automatic air purger-vent shall be factory provided for field installation.

The drycooler shall provide \_\_\_\_\_ BTUH total heat rejection at a flow rate of \_\_\_\_\_ GPM with \_\_\_\_\_ °F EGT and \_\_\_\_\_ °F LGT at \_\_\_\_\_ °F ambient air temperature. Each pump shall be \_\_\_\_\_ Hp and shall be sized to provide \_\_\_\_\_ GPM @ \_\_\_\_\_ Ft. w.g. total system head. The glycol solution shall be \_\_\_\_\_ % (*ethylene or propylene*) by volume.

The drycooler and pump package shall be designed for \_\_\_\_\_ Volt, \_\_\_\_\_ Phase, \_\_\_\_\_ Hertz main power supply.

## 2.4 Options

### 2.4.1 CONTROL OPTIONS

**2.4.2.1 MC-3000™, Advanced Microprocessor Dew Pt Controller w/ Alarms**



The system shall be provided with a MC-3000™ advanced microprocessor based controller with 100% outside air dew point temperature control algorithm logic. The controller shall also include free-economizer cooling and proportional analog (0-10Vdc) reheat/heat control.

**Select Features/Benefits:**

- 4x20 Character Liquid Crystal Alpha-numerical Display
- User Configurable
- Run-Time Hours
- Current Unit Mode Status
- Alarm Status

- Digital & Analog Inputs / Outputs
- Temperature Anticipation
- Remote Stop / Start Contact
- Summary Alarm Contact
- Automatic or Manual (selectable) Restart After Power Loss
- Sequential Load After Restart
- Recovery Delay
- Compressor Short Cycle Timers
- Cold Start Time Delay
- Security Password Access
- Self-Diagnostics
- Service Mode

## Unit Status Display

The control system shall display current unit functions and room status (if applicable):

- Current Dry Bulb Temp Set Point
- Current Relative Humidity Set Point
- System ON/OFF
- Cooling
- Heating
- Humidifying
- Dehumidifying
- Reheating
- Actual Room DB Temperature
- Actual Room Relative Humidity

## Alarm Conditions:

Alarm conditions activate an audible and visual indicator plus close a summary alarm dry contact connection. The control system shall alert to the following alarm conditions (if applicable):

- High Temperature
- Low Temperature
- High Humidity
- Low Humidity
- Sensor Failure
- Summary Failure
- High Head Press
- Smoke Detection
- Firestat
- Leak Detection
- Sensor Failure
- Loss of Power
- Loss of Air Flow (optional)
- Dirty Filter (optional)

## □ 2.4.2.1.1 BMS Communications

- ModBus RS485 Serial Connection
- BACnet over MS/TP (RS485 Serial)
- BACnet Over IP (Ethernet / EIA485)
- LonWorks FTT10 (RS485 Serial)

## 2.4.3 REHEAT / HEAT OPTIONS

### □ 2.4.3.1 Hot Gas Reheat

The system shall be provided with a hot gas reheat coil with modulating 3-way control valve. The hot gas reheat coil shall be sized to provide free-energy space neutral leaving air temperature by offsetting the sensible cooling during dx compressor operation.

### □ 2.4.3.2 Electric Duct Heater



An electric duct mounted heater shall be factory provided for field installation. The duct heater shall be the open wire nichrome element type complete with individual heater stage starter/contactors, air flow switch and overheat safeties. The duct heater shall require a separate main power supply from the unit. The electric heat shall have a capacity of \_\_\_\_\_ BTU/HR and a KW rating of \_\_\_\_ KW, controlled in \_\_\_ stages.

### □ 2.4.3.2.1 SCR Fired Electric Heater

The electric heat shall be controlled through a "zero firing" silicon control rectifier (SCR) with an extruded aluminum heat sink and solid state logic system to provide close dry bulb temperature control of the leaving conditioned air temperature. The electric heat shall have a capacity of \_\_\_\_\_ BTU/HR and a KW rating of \_\_\_\_ KW.

## 2.5 Accessories

### □ 2.5.1 CO2 Sensor (Wall or Duct Mtd)



A non-dispersive infrared carbon dioxide (CO2) sensor shall be factory provided for unit or field (duct or wall) installation. The CO2 sensor shall measure environmental carbon dioxide levels for use in demand-controlled ventilation, air-quality monitoring, and other HVAC applications in accordance with ASHRAE standards. Fully isolated analog outputs and a convenient center wiring terminal shall make installation both simple and trouble-free. The analog output shall be jumper-selectable, 4-20 mA or 0-10 VDC, over the industry standard 0-2000 ppm CO2 range. LCD display and control relay with adjustable setpoint shall be provided.

#### FEATURES:

- 24 VAC/VDC power
- 0-10 VDC or 4-20 mA analog output, jumper selectable

- 0-2000 ppm CO2 range
- Wall and Duct Mtd Sampling versions
- Isolation of output and power
- Compact, attractive enclosure
- Control relay with adjustable setpoint
- Simple single-point calibration

### □ 2.5.2 Condensate Pump



A condensate pump shall be factory provided for field installation. The condensate pump shall be provided with dual internal float switches: one for pump operation initiation and the other for pump reservoir overflow safety. The condensate pump shall be powered through A/C unit main power via Optional "Condensate Pump Fused Powered Terminal Connection".

### □ 2.5.3 Main Power, Non-Fused Disconnect



A main power non-fused disconnect shall be factory provided for field installation. The disconnect shall be NEMA rated for indoor or outdoor installation as required.

### □ 2.5.4 Firestat



A Firestat shall be factory provided for field installation in the return air duct and wired to the A/C unit electrical control panel. The Firestat shall shut-down all A/C system operations upon sensing a high return air temperature condition.

### □ 2.5.5 Smoke Detector



A Smoke Detector shall be factory

provided for field installation in the return air duct and wired to the A/C unit electrical control panel. The Smoke Detector shall shut-down all A/C system operations upon activation.

## 2.5.6 Remote Water-Leak Detector

A remote water-leak detector shall be factory provided for field installation. The remote water-leak detector shall be wired to shut down all A/C unit water producing functions upon sensing a water leak.

## 2.5.7 Mounting Vibration Isolators

### 2.5.7.1 Neoprene Mtd Isolators

Each indoor vertical floor mounted section shall be provided with neoprene vibration mounting isolators sized for the total distributive weight of the unit.

### 2.5.7.2 Spring Mtd Isolators



Each indoor vertical floor mounted section shall be provided with adjustable spring vibration mounting isolators with non-skid neoprene acoustical isolation pads. Isolators shall sized for the total distributive weight of the unit with a 1" deflection.

## 2.5.8 Compressor Acoustic / Sound Jackets

Each compressor shall be provided with a factory installed compressor sound jacket with snap closure system for ease of removal and reinstallation. Sound jackets shall have a noise reduction coefficient (NRC) of 85 per ASTM and C-423 and a sound transmission lost (STC) of 11 per ASTM E-90.



### Ceiling Air Conditioners

**SpotCool™** - 2x4 T-Bar "Spot-Cooler" Comfort & Precision Ceiling Mounted A/C's

**HK™ Horizontal** - Hi-Static Ducted "Same-Face" Comfort & Precision Ceiling Mounted A/C's

**HK-OA™** - Horizontal 100% Outside Air Ceiling Mounted A/C's

### Floor Air Conditioners

**VK™ Vertical** - SCAV, Vertical Floor Mounted Self-Contained & Split Comfort A/C's & Heat Pumps

**VK-OA™** - VertiKu™ 100% Outside Air Vertical Floor Mounted A/C's

**MissionCritical™** - Precision Vertical Floor Mounted Computer Room A/C's

### Air Purification Systems

**PureAir™** - Ceiling Mounted 2x4 T-Bar Grille and Ducted Air Cleaners (Hepa, UV & Ionization ...)

### Remote Heat Rejection

**FluidCool™** - Indoor & Outdoor Remote Glycol Drycoolers

**PumpAll™** - Single & Dual Standard plus "All-In-One" Integrated Glycol Pump Packages



**2x4 "Spot-Cooler" Ceiling Mounted A/C's**  
(1 to 3 Tons)

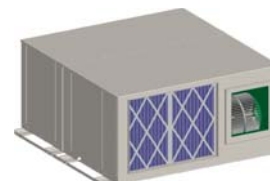

**Ducted "Same-Face" Ceiling Mounted A/C's**  
(1 to 15 Tons)

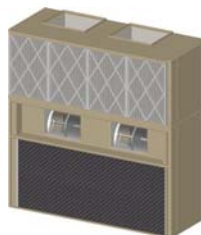

**Comfort - Packaged & Split Vertical Floor Mounted Air Conditioners**  
(3 to 30 Tons)



**Precision - Vertical Floor Mounted Computer Room Air Conditioners**  
(1 to 30 Tons)



**PureAir™ - 400 to 3,000 CFM 2x4 T-Bar & Ducted Air Cleaning Purification Systems**  
(Hepa, Carbon Filtration plus Ultra-Violet and Ionization Tube Technologies ...)

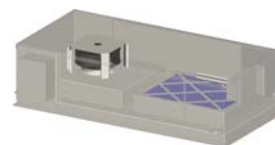

**Remote Air Cooled Condensers, Condensing Units & Glycol Drycoolers**  
(1 to 180 Tons of THR)

**Single, Dual & Triplex Glycol Pump Packages**  
(1/2 to 50 HP)



[www.aboveair.com](http://www.aboveair.com)



5179 Mountville Road  
Frederick, Maryland 21703, U.S.A.  
Phone: 301-874-1130, Facsimile: 301-874-1131  
Email: [sales@aboveair.com](mailto:sales@aboveair.com)

Copyright 05/10  
Form: VKOA-L23

Specifications are subject to change without notice.