

### RT-OA Primary Space Control

The MC-9000P control sequence provides temperature and humidity control of a single zone. This control sequence is applied for high percentage outdoor air situations (>20% OA) where a single unit is required to meet both the outdoor air requirement as well as controlling the space temperature.

#### **Unit Operation**

Unit operation is initiated when all points are in their run positions.

**System Enable:** The system enable is controlled at the unit's display terminal, within the system enable menu.

**Remote Stop/Start:** Remote stop/start NC contacts are provided on all units and ship from the factory jumpered for continuous operation.

**BMS Control:** The unit is provided with an optional point that may be written by a BMS to index unit operation.

**Schedule Control:** The unit is provided with a local schedule that may be set to operate the unit in Occupied or Unoccupied modes based on its time clock.

#### **Supply Fan Operation**

When the unit is indexed for operation and in its occupied mode, the EC (electronically commutated) supply fan shall be energized after a 30 second delay (adj.) to allow for optional control damper actuation. The fan shall ramp up gently and run continuously. After an additional 15 second delay (adj.) to allow for air proving, the unit shall operate as described herein.

**Set Point Control (Standard):** The fan will not modulate and will operate at a constant set point (100%, adj.) as determined during system start-up and balancing or as written by BMS input.

**Single Zone VAV Control (Optional):** The fan shall operate at its minimum output (50%, adj.) during normal operation and during dehumidification or humidification modes. The fan shall ramp from its minimum output to its maximum output (100%, adj.) on a rise above the cooling set point or fall below the heating set point by 2°F (adj.).

#### **Zone Reset Operation**

The unit provides automatic change-over between cooling, dehumidification, and heating operation. The space cooling and heating set points are separated by a dead band (5°F, adj.) to minimize unit cycling and prevent simultaneous cooling and heating.

Space heating and cooling is accomplished via a supply air temperature reset schedule. An optional dew point set point reset schedule is also available for space humidity.

When the unit is indexed for Cooling/Dehumidification operation, the unit shall operate based on its cooling set point (75°F, adj.) and its cooling reset band (2°F, adj.). The active supply air temperature set point shall reset linearly between neutral air (75°F, adj.) and its design cooling condition (55°F, adj.) as the space temperature increases.

When the unit is indexed for Heating operation, the unit shall operate based on its heating set point (70°F, adj.) and its heating reset band (2°F, adj.). The active supply air temperature set point shall reset linearly between neutral air (70°F, adj.) and its design heating condition (95°F, adj.) as the space temperature decreases.

#### **Dehumidification & Cooling Operation**

On a rise in the mixed air dew point temperature (MADP) by 2°F (adj.) above the dew point set point (55°F, adj.) or on a rise in mixed air temperature (MAT) by 2°F (adj.) above the cooling set point (75°F, adj.), the unit shall enable compressor operation.

Compressor 1 shall be energized at 100% and modulate to meet the DX cooling coil leaving air temperature (dxLAT) set point (55°F, adj.) based on an adjustable cooling PID control loop. After a minimum delay of 3 minutes, if Compressor 1 is operating at 100% capacity and unable to meet the supply air temperature set point, the Compressor 2 shall be energized (if applicable).

On a fall in dxLAT below set point and Compressor 1 operating at its minimum

capacity (20%), Compressor 2 shall be de-energized. Compressor 1 shall continue to modulate to maintain the dxLAT set point.

On a fall in MADP by 2°F (adj.) below the dew point set point and in MAT by 2°F (adj.) below the cooling set point, Compressor 1 shall be de-energized

On a fall in MAT below 60°F (adj.) by 2°F (adj.), then dehumidification and cooling operation shall be locked out.

Dual Tandem Systems: Compressors 1 & 3 and 2 & 4 sequence in parallel.

#### **Reheat Operation**

If the unit is operating in its cooling or dehumidification mode and the supply air temperature (SAT) falls below the cooling set point (75°F, adj.), the hot gas reheat valve shall be enabled. The hot gas reheat valve shall modulate to meet the cooling set point based on the adjustable hot gas reheat PID control loop.

On a rise in SAT above the cooling set point by 2°F (adj.), the hot gas reheat valve shall be disabled.

#### **Airside Economizer**

If the outside air condition is below the economizer dry bulb set point (69°F, adj.), the unit shall modulate the economizer dampers open. If the outdoor air temperature falls below 55°F (adj.), mechanical cooling shall be locked out and the dampers shall modulate to maintain 55°F into the unit. The unit may optionally be provided with a dry bulb + enthalpy operation. The economizer is enabled in enthalpy mode if the outdoor air enthalpy falls below the enthalpy set point (enthalpy @ 75°F/50%RH, adj.)

On a fall in space temperature, the dampers shall return to their normal positions.

**CO2 Damper Control (Optional):** The economizer damper may also be set to respond to space CO2 level to provide demand control ventilation. If the space CO2 level rises above the CO2 set point (500 ppm, adj.) by 50 ppm, the damper shall open to provide the unit's maximum outdoor air supply. On a fall in space CO2 level, the damper shall return to its minimum position. If both economizer and CO2 operation are required simultaneously, the damper shall open to satisfy the larger requirement.

#### **Heat Operation (Gas Heat Option)**

Gas heat operation shall be locked out during cooling/dehumidification operation. Compressors and gas heat may not operate simultaneously.

On a fall in SAT by 2°F (adj.) below the heating set point (70°F, adj.), the unit shall enable heater operation. The heater shall modulate to meet the heating set point based the adjustable heating PID control loop.

On a rise in SAT above the heating set point by 2°F (adj.), the heater shall be disabled.

Refer to the Heatco control sequence for more detailed information about gas heater staging and modulation.

#### **Heat Operation (Electric Heat Option)**

Hot water/steam heat operation shall be locked out during cooling/dehumidification operation. Hot water or steam heat may be enabled as reheat at the discretion of the engineer, as allowable in compliance with their code requirements.

On a fall in SAT by 2°F (adj.) below the heating set point (70°F, adj.), the unit shall enable heater operation.

Heaters ≤ 45 amps: The SCR heater shall modulate to meet the heating set point based on the heating PID control loop.

Heaters > 45 amps: The heater shall be controlled in up to 8 stages by a Vernier controller with a final SCR stage. The stages shall engage with a 2 minute delay (adjustable), with the final SCR stage modulating to maintain the heat set point based on the heating PID control loop.

On a rise in SAT above the heating set point by 2°F (adj.), the heater shall be disabled.

### Heat Operation (Hot Water or Steam Option)

Hot water/steam heat operation shall be locked out during cooling/dehumidification operation. Hot water or steam heat may be enabled as reheat at the discretion of the engineer, as allowable in compliance with their code requirements.

On a fall in SAT by 2°F (adj.) below the heating set point (70°F, adj.), the unit shall enable heater operation. The heater shall modulate to meet the heating set point based the adjustable heating PID control loop.

On a rise in SAT above the heating set point by 2°F (adj.), the heater shall be disabled.

### Heat Operation (Heat Pump Option)

*For heat pump units, the reversing valve(s) are normally open in heating operation, closed in cooling/dehumidification operation.*

Heat pump operation is available when cooling & dehumidification operation is locked out. Air-source heat pumps are locked out when the MAT falls below 45°F.

On a fall in dxLAT below the heating set point (70°F, adj.) by 2°F (adj.), the unit shall enable heat pump operation. Compressor 1 shall be energized at 100% and modulate to meet the heating set point based on the adjustable heat pump PID control loop. After a minimum delay of 3 minutes, if Compressor 1 is operating at 100% capacity and the unit is unable to meet the heat set point, Compressor 2 shall be energized (if applicable).

On a rise in dxLAT above set point and Compressor 1 operating at its minimum capacity (20%), Compressor 2 shall be de-energized. Compressor 1 shall continue to modulate to maintain the heating set point. On a continued rise in dxLAT above the heating set point by 2°F (adj.), the Compressor 1 shall be denegized.

Dual Tandem Systems: Compressors 1 & 3 and 2 & 4 sequence in parallel.

Air-Source Heat Pumps Only, Defrost Cycle: The defrost cycle shall ensure that the outdoor coil does not freeze. After 30 minutes of accumulated compressor run-time, if the defrost temperature switch mounted on the coil opens, the system shall enter its defrost mode. Condenser fans shall be shut down and the reversing valve shall switch to its cooling position. The unit shall remain in its defrost mode until the defrost temperature switch closes or for a maximum defrost run time of 5 minutes. The auxiliary heat stage shall be enabled and operate as described herein.

### Energy Recovery Wheel Operation (Optional)

The total energy recovery wheel shall be enabled whenever the unit is operating. When the outdoor air temperature (OAT) rises above the return air temperature (RAT) by 2°F (adj.), the wheel shall operate at its maximum speed.

On a fall in OAT below RAT by 2°F (adj.), the wheel shall modulate its speed to maintain the heating set point based on the adjustable energy recovery wheel PID control loop.

Wheel Freeze Protection & Defrost Control: On a fall in the exhaust air temperature (EAT) below the freeze set point (34°F, adj.), the wheel slows down to a minimum speed to prevent freezing.

### Electric Preheat Operation (Optional)

Preheat operation shall be enabled when the preheat temperature (PHT) falls below the preheat set point (34°F, adj.) by 2°F (adj.). The electric preheat shall be controlled in up to 4 stages. The stages shall engage with a 2 minute delay (adjustable).

On a rise in PHT above the preheat set point by 2°F (adj.), electric preheat shall be disabled.

### Exhaust Fan Operation (Optional)

The EC exhaust fan motor shall ramp up gently and operate continuously while the supply fan is operating.

Set Point Control (Standard): The fan will not modulate and will operate at a constant set point (100%, adj.) as determined during system start-up and balancing or as written by BMS input.

Static Pressure Control (Optional): The fan shall vary its speed to maintain the static pressure set point (1.0" w.g., adj.), based on an adjustable PID control loop and a duct-mounted or building static pressure sensor.

### Head Pressure Control (Air-Cooled Units)

The EC condenser fan motor shall ramp up gently and operate continuously while the compressors are operating. The fan shall vary its speed to maintain the head pressure set point (325 psig, adj.), as controlled by the adjustable head pressure control PID loop.

Heat pumps only: When the unit is operating in its heating mode, the fan shall ramp to 100% output. When the unit enters into its defrost cycle, the fan output shall drop to 0%.

### Head Pressure Control (Water-Cooled Units)

On a call for compressor operation, the compressor start shall be delayed for 60 seconds (adj.) to allow the valve to fully open. After an initial modulation delay of 90 seconds (adj.), the valve shall modulate between its minimum and maximum operating positions based on the adjustable head pressure control PID loop.

Heat pumps only: When the unit is operating in its heating mode, the valve shall open to its maximum position and cease modulation.

### Unoccupied Operation

If the unit utilizes the system schedule, then optional unoccupied heating (60°F, adj.) and cooling (80°F, adj.) set points may be set. If the space temperature falls below or rises above these points, respectively, then the unit shall start its supply fan and operate as described herein. The OA damper may be set for normal operation or to remain closed during unoccupied hours.

### System Alarms

Air Proving: An adjustable differential pressure switch closes to confirm airflow prior to the activation of other mechanical components. If the switch doesn't close after an adjustable time delay or opens during unit operation, the unit shall lock-out operation and enunciate an alarm.

Dirty Filter: An adjustable differential pressure switch shall open when the pressure drop across the filter exceeds the desired pressure drop and enunciates an alarm.

Condensate Alarm: A condensate pan switch is factory installed in the drain pan detect high condensate. On a high condensate condition, the circuit will open and shut down all mechanical cooling or lock-out unit operation (optional) and enunciate an alarm.

High Refrigerant Pressure: The high refrigerant pressure (>600 psig, auto-reset) switch shall open on a high pressure condition and shut down compressor operation. If the switch resets, the system will attempt to restart the compressor up to 3 times in 10 minutes. If the switch does not reset within 90 seconds or on 3 failed start attempts, the system shall lock-out compressor operation, and enunciate an alarm.

Low Refrigerant Pressure: The low refrigerant pressure (<50 psig) shall open on a low pressure condition and after a time delay (90s, adjustable), shall lock-out compressor operation and enunciate an alarm.

Smoke Detector: Normally closed smoke detector contacts are provided for field wiring on all units. The unit shall shut-down all operation and enunciate an alarm immediately upon contact opening. These contacts may optionally be set for emergency fan purge; all cooling and heating components shall shut down, but fans will operate at maximum output while the contact remains open.

Firestat: Normally closed firestat contacts are provided for field wiring on all units. The unit shall shut-down all operation and enunciate an alarm immediately upon contact opening.

Sensor Failure: If a sensor is reading out of range for 5 minutes, the unit shall enunciate an alarm to indicate an issue with the sensor.

High and Low Limit Alarms: Adjustable high and low limit alarms are user-adjustable for sensor points.

### Sensor Schematic

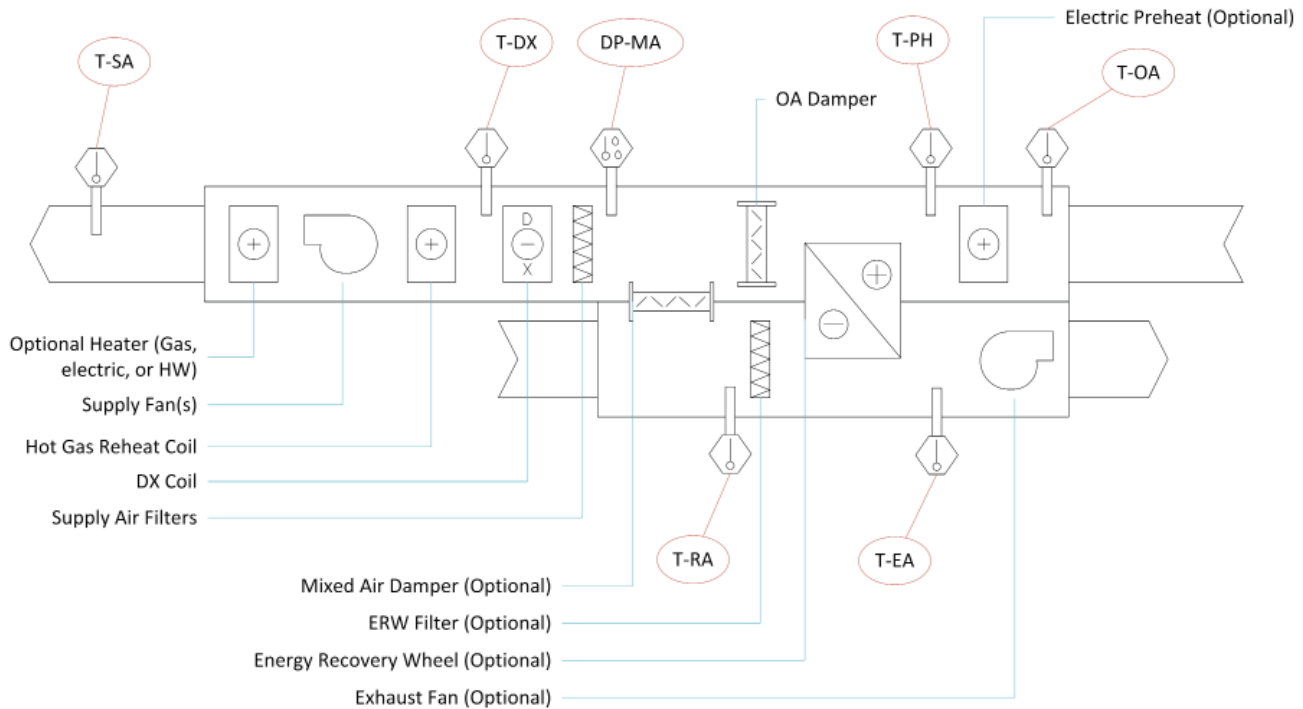

All sensors included with your unit for field installation must be installed prior to start-up or the unit will not operate properly. Sensors are typically either NTC, 4-20mA, or 0-5 VDC.

#### Factory Installed Sensors

**DP-MA:** The factory-mounted mixed air dew point (temperature/humidity) sensor is installed in the mixing section immediately prior to the filter box.

**P-HEAD1(, 2) (Not Shown):** The head pressure sensor is factory installed. Refer to piping diagrams for location detail.

**P-SUCT1(, 2) (Not Shown):** The suction pressure sensor is factory installed on units with electronic expansion valves. Refer to piping diagrams for location detail.

**T-DX:** The DX leaving air temperature sensor is factory-installed between the DX coil and the hot gas reheat coil.

**T-EA:** The exhaust air temperature sensor is factory-installed after the energy recovery wheel. This sensor is only provided when the ERW option is selected.

**T-OA:** The outside air temperature sensor is factory-installed in the outside air stream. This sensor is only provided when the ERW or airside economizer option is selected. This sensor may alternately be provided as a combination temperature & humidity sensor if the dry bulb + enthalpy set point economizer control option is selected.

**T-PH:** The factory-mounted preheat temperature sensor is installed after the electric preheat stage, prior to the ERW (optional). The sensor is only provided when the preheat option is selected.

**T-RA:** The return air temperature sensor is factory-installed prior to the energy recovery wheel. This sensor is only provided when the ERW option is selected.

**T-SUCT1(, 2) (Not Shown):** The suction temperature sensor is factory installed on units with electronic expansion valves. Refer to piping diagrams for location detail.

#### Field Installed Display

**Unit Display:** All units are shipped with a display terminal and a 10 foot (standard) for connection in the unit's electrical box. The display terminal does not contain any sensors. Cables up to 200 foot in length are available for remote mounting the display in another location. This terminal is required for unit operation.

#### Field Installed Sensors

**A-CO2 (Optional, Not Shown):** A CO2 sensor (duct or space mounted) is provided with the demand control ventilation option. Duct mounted sensors are field installed in the common return/exhaust duct; space mounted sensors are field mounted in the space 60" AFF away from heat and humidity sources or as directed in the contract documents.

**P-BP (Optional, Not Shown):** A differential pressure sensor is provided with the static pressure control option or exhaust air static pressure control option (building differential static pressure sensor option). This sensor is field mounted as directed on the contract documents.

**P-EA (Optional, Not Shown):** A differential pressure sensor is provided with the exhaust static pressure control option (duct-mounted static pressure option). This sensor is field mounted in the exhaust air duct as directed on the contract documents.

**T-SA:** The supply air temperature sensor is shipped loose for field installation. This sensor must be installed downstream of the unit in a straight section of duct at least 3 duct-widths downstream of the unit.

**T-SPACE (Not Shown):** The space temperature sensor is shipped loose for field installation. This sensor must be field mounted in the space 60" AFF away from heat and humidity sources or as directed in the contract documents. This sensor may alternately be provided as a duct-mounted sensor. A combination temperature & humidity sensor may be provided in lieu of temperature-only if the dew point reset option is selected.