

LEGEND

- ** FACTORY PROVIDED, FIELD WIRED BY OTHERS
- ^^ REFER TO DETAILS
- ① TERMINAL
- FIELD WIRING
- FACTORY JUMPER OR AUX DEVICE
- 24V POWER
- COMMON
- 24V CONTROL OUTPUT
- 24V CONTROL INPUT
- ALARM/DRY CONTACT
- SHIELDED CABLE

GENERAL CONTROL NOTES

- VDC SIGNALS ARE POLARITY SENSITIVE, FAILURE TO OBSERVE POLARITY MAY RESULT IN IMPROPER OPERATION AND DAMAGE TO SENSORS OR OTHER DEVICES.
- SENSOR CONNECTIONS SHOULD USE SHIELDED, MULTI-CORE CABLE WITH 3-5 CONDUCTORS, THE FOLLOWING WIRE SIZES ARE ACCEPTABLE:
 - UP TO 200'; 20 AWG
 - 201' - 350'; 18 AWG
 - 351' - 500'; 16 AWG
- 24VAC AND COMMON TERMINALS CONNECTED VIA CENTRAL JUMPER.
- DISPLAY TERMINAL DOES NOT CONTAIN SENSORS, CABLE FOR CONNECTION IS PROVIDED BY THE FACTORY.
- ALL DEVICES ARE WIRED THROUGH NC CONTACTS AND ALARM ON LOSS OF 24VAC SIGNAL.
- FACTORY INSTALLED JUMPERS MUST REMAIN IN PLACE OR BE WIRED THROUGH THE INDICATED DEVICE.
- VALVES, SCR HEATERS, AND OTHER DEVICES MAY BE FACTORY MOUNTED OR FIELD WIRED, REFER TO YOUR SUBMITTAL FOR MORE INFORMATION.
- FIELD SUPPLIED DAMPERS, VALVES, SOLENOIDS, ETC. MAY NOT BE POWERED FROM UNITS TRANSFORMERS UNLESS SPECIFICALLY NOTED.

COMMON CONTROL ABBREVIATIONS

- APS AIR PROVING SWITCH
- ASE AIR SIDE ECONOMIZER
- CC# COMPRESSOR CONTACTOR 1,2,...
- CNCD#R# CONDENSER CONTACTOR/RELAY 1,2,...
- CNDV CONDENSER VALVE
- COR CONDENSATE OVERFLOW RELAY
- CPS CONDENSATE PAN SWITCH
- CWV CHILLED WATER VALVE
- DER DAMPER ENABLE RELAY
- DFS DIRTY FILTER SWITCH
- DTS# DISCHARGE TEMPERATURE SWITCH 1,2,...
- DUS# DIGITAL UNLOADER SOLENOID 1,2,...
- EVP#R# EVAPORATOR CONTACTOR/RELAY
- FCS FAN CYCLING SWITCH
- FCV FREECOOL VALVE
- HGRV HOT GAS REHEAT VALVE
- HGS# HOT GAS SOLENOID 1,2,...
- HCR# HEATER CONTACTOR/RELAY 1,2,...
- HUM# HUMIDIFIER CONTACTOR
- HPS# HIGH PRESSURE SWITCH 1,2,...
- HWV HOT WATER VALVE
- LLS# LIQUID LINE SOLENOID 1,2,...
- LPS# LOW PRESSURE SWITCH 1,2,...
- LSR LIFE SAFETY RELAY
- OHS OVERHEAT SWITCH
- REVV# REVERSING VALVE SOLENOID 1,2,...
- STV STEAM VALVE
- TRF# TRANSFORMER 1,2,...
- VFD VARIABLE FREQUENCY DRIVE

SPECIAL CONTROL NOTES

1. REMOTE STOP/START JUMPER, NC SWITCH MUST HAVE MINIMUM 75 VA RATING.
2. WATER LEAK DETECTOR POINT OF CONNECTION, REFER TO WATER LEAK DETECTOR WIRING IF DEVICE IS PROVIDED.
3. CONDENSATE PUMP OVERFLOW SWITCH POINT OF CONNECTION, REFER TO CONDENSATE PUMP WIRING IF DEVICE IS PROVIDED.
4. SMOKE DETECTOR POINT OF CONNECTION, REFER TO SMOKE DETECTOR WIRING IF DEVICE IS PROVIDED.
5. FIRESTAT POINT OF CONNECTION, REFER TO FIRESTAT WIRING IF DEVICE IS PROVIDED.
6. EVPR PROVIDED FOR CONNECTION TO OPTIONAL FIELD-INSTALLED VFD KIT.
7. DX UNITS INCLUDE STANDARD HIGH AND LOW PRESSURE SWITCHES FOR EACH CIRCUIT (OCCUPY 2 DIGITAL INPUTS PER CIRCUIT).
8. STANDARD MINIMUM TERMINAL CONFIGURATION: TERMINALS PROVIDED WILL VARY BASED ON UNIT CONFIGURATION.
9. LIFE SAFETY (FIRE/SMOKE ALARM) MAY ALTERNATELY BE ORDERED AS A DIGITAL INPUT TO THE CONTROLLER.

SENSOR LEGEND

TH-SPACE: SPACE TEMPERATURE & HUMIDITY SENSOR (NTC/4-20 mA).

A TYPICAL CONTROLLER IS SHOWN HERE. FINAL CONTROLLER AND/OR EXPANSIONS INSTALLED IN YOUR UNIT WILL BE DETERMINED BASED ON THE FEATURES PURCHASED AND REQUIRED I/O CONNECTIONS. SPARE I/O FOR FEATURES NOT SPECIFIED ON THE SUBMITTAL AND FINAL PURCHASE ORDER PROVIDED TO ABOVEAIR MAY BE AVAILABLE.

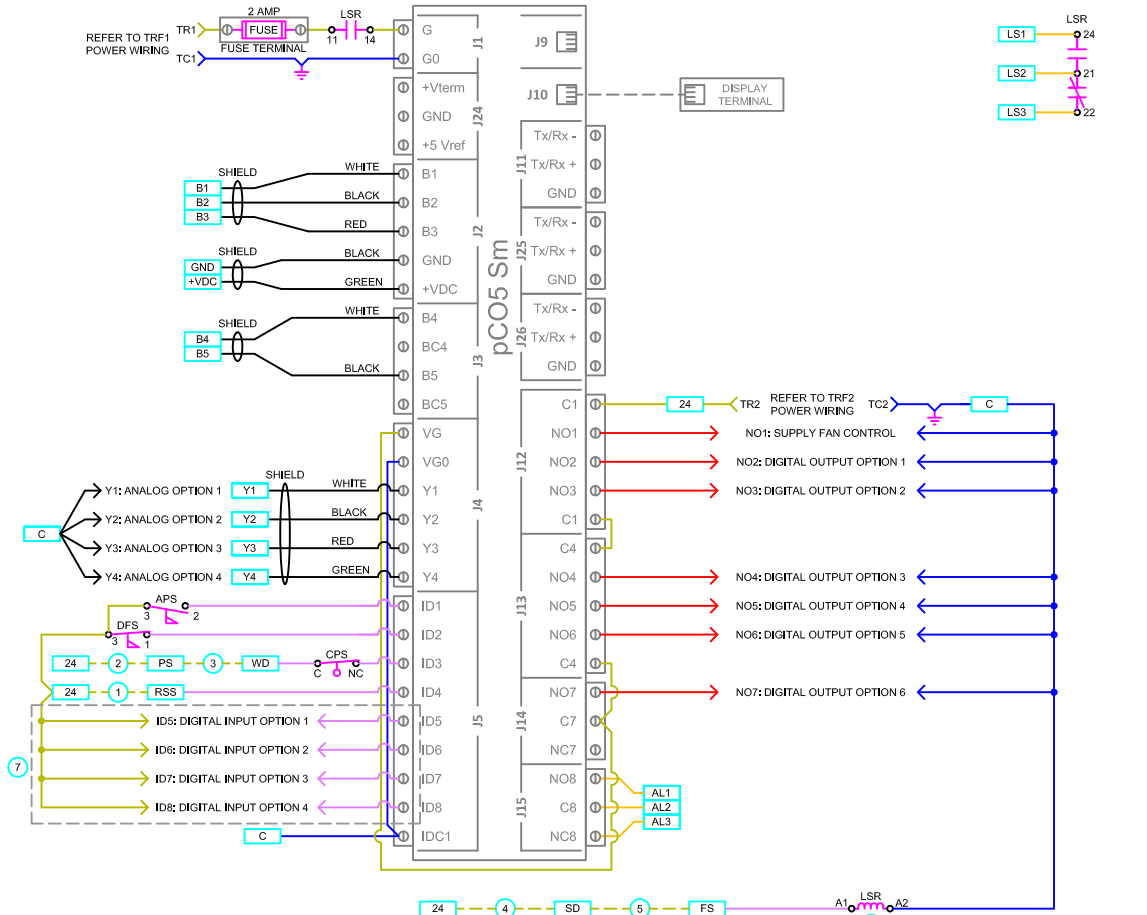

ADDITIONAL SENSOR OPTIONS	
1.	FREECOOL/CONDENSER WATER TEMPERATURE SENSOR
2.	CO2 SENSOR
3.	MIXED AIR TEMPERATURE
4.	OUTDOOR AIR TEMPERATURE
5.	HEAD PRESSURE
6.	SUCTION PRESSURE
7.	SUPPLY TEMPERATURE
ANALOG (0-10 VDC) OUTPUT OPTIONS	
1.	DIGITAL SCROLL COMPRESSOR
2.	CHILLED WATER VALVE
3.	HEAD PRESSURE CONTROL (COND VALVE OR FAN)
4.	SCR ELECTRIC HEAT OR PREHEAT
5.	HOT WATER OR STEAM HEAT OR PREHEAT
6.	HOT GAS REHEAT
7.	HUMIDIFIER
8.	FREECOOLING VALVE (WATER SIDE ECONOMIZER)
9.	AIRSIDE ECONOMIZER DAMPERS
DIGITAL INPUT OPTIONS	
1.	LIFE SAFETY ALARM (ALTERNATE CONNECTION)
2.	DIFFERENTIAL PRESSURE WATER FLOW PROVING SWITCH
3.	HEAT PUMP DEFROST THERMOSTAT
4.	EVAPORATOR DAMPER END SWITCH
5.	CONDENSER DAMPER OR VALVE END SWITCH
6.	COMPRESSOR LOCKOUT
7.	PUMP INTERLOCK
DIGITAL OUTPUT OPTIONS	
1.	COOL STAGES
2.	HEAT STAGES
3.	HOT GAS REHEAT
4.	HEAT PUMP REVERSING VALVE
5.	HUMIDIFIER
6.	PREHEAT STAGE
7.	FREECOOLING VALVE (WATER SIDE ECONOMIZER)
8.	PUMP/CONDENSER VALVE ENABLE RELAY
9.	DAMPER ENABLE RELAY
10.	AUX FAN RELAY

TERMINAL STRIP SUMMARY

LS1	LIFE SAFETY RELAY DRY CONTACTS
LS2	
LS3	
24	24 VAC CONTACTS
24	
24	
24	
RSS	
WD	AUXILIARY INPUT CONTACTS
PS	
SD	
FS	
C	COMMON CONTACTS
C	
C	
B1	SENSOR CONTACTS
B3	
+VDC	SENSOR +VDC POWER CONTACTS
GND	

