

MC-2000SZ Single Zone VAV Control

The MC-2000SZ control sequence is a variable volume control sequence which provides temperature and humidity control of a single zone. Both the fan speed and supply air temperature will vary according to the requirements of the single zone. The outdoor air percentage should be no greater than 20%.

Unit Operation

Unit operation is initiated when all points are in their run positions.

System Enable: The system enable is controlled at the unit's display terminal, within the system enable menu.

Remote Stop/Start: Remote stop/start NC contacts are provided on all units and ship from the factory jumpered for continuous operation.

BMS Control: The unit is provided with an optional point that may be written by a BMS to index unit operation.

Schedule Control: The unit is provided with a local schedule that may be set to operate the unit in Occupied or Unoccupied modes based on its time clock.

Fan Control

When the unit is indexed for operation and in its occupied mode, the supply fan shall be energized after a 30 second delay (adj.) to allow for optional control damper actuation. The fan shall run continuously. After an additional 15 second delay (adj.) to allow for air proving, the unit shall operate as described herein.

The fan shall operate at its minimum output (30 Hz/50%, adj.) during normal operation and during dehumidification or humidification modes. The fan shall ramp from its minimum output to its maximum output (60Hz/100%, adj.) on a rise above the cooling set point or fall below the heating set point by 2°F (adj.).

System Mode

The unit provides automatic change-over between cooling, heating, dehumidification, and humidification operation. The cooling and heating set points are separated by a dead band (5°F, adj.) to minimize unit cycling and prevent simultaneous cooling and heating. The dehumidification and humidification set points are also separated by a dead band (10%RH, adj.) to prevent simultaneous dehumidification and humidification operation.

Cooling Operation

On a rise in space temperature by 1°F above the cooling set point (75°F, adj.), the unit shall energize its first compressor stage. *The first compressor shall energize at 100% and modulate to meet the cooling supply air set point (55°F, adj., digital scrolls only).* For dual circuit units, on a rise in space temperature by an additional 1°F, and a minimum delay of 3 minutes, the second compressor stage shall energize.

On a fall in space temperature, the second compressor stage (if applicable) shall de-energize. On a continued fall in space temperature, the first compressor stage shall be de-energized.

All compressors are subject to a minimum run time of 3 minutes and a minimum off time of 3 minutes to prevent short cycling.

Economizer (Air-Side Economizer, Optional)

If the outside air condition is below the economizer set point (69°F, adj.), the unit shall modulate the economizer dampers open. If the outdoor air temperature falls below 55°F (adj.), mechanical cooling shall be locked out and the dampers shall modulate to maintain 55°F into the unit.

On a fall in space temperature, the dampers shall return to their normal positions.

CO2 Damper Control (Optional): The economizer damper may also be set to respond to space CO2 level to provide demand control ventilation (<20% outdoor air). If the space CO2 level rises above the CO2 set point (700 ppm, adj.) by 50 ppm, the damper shall open to provide the unit's maximum outdoor air supply (<20%). On a fall in space CO2 level, the damper shall return to its minimum position. If both economizer and CO2 operation are required simultaneously, the damper shall open to satisfy the larger requirement.

Freecool (Water-Side Economizer, Water Cooled Only, Optional)

If the condenser water temperature is below the freecool set point (45°F, adj.), the unit shall energize its freecooling valve as its first stage of cooling in lieu of the first

compressor stage. *The valve shall modulate to meet the cooling supply air set point (55°F, adj., modulating valves only).*

On a fall in space temperature, the freecool valve shall be de-energized.

On a continued rise in space temperature by 1°F and a minimum delay of 3 minutes, the freecool valve shall be de-energized and the unit shall sequence its mechanical cooling stages to meet the temperature requirement.

Dehumidification Operation

If the unit is not operating in its cooling or heating mode and on a rise in space humidity above set point (55%RH, adj.) by 1%RH, the unit shall enter its dehumidification mode. The unit shall energize its first compressor. *The first compressor shall energize at 100% and modulate to meet the suction pressure set point (120 psig, digital scrolls only).* The hot gas reheat coil (first reheat stage during dehumidification, if applicable) and/or heating stages (optional) shall energize to maintain a neutral air temperature, as described under the reheat operation section.

On a fall in space humidity, the first compressor shall be de-energized.

Reheat Operation

On a fall in the supply air temperature by 1°F below the heating set point (70°F, adj.), the unit shall energize its first reheat stage. *The first reheat stage shall modulate to maintain a neutral air temperature (70°F, adj., SCR or modulating valves only).* On a continued fall in the supply air temperature by an additional 1°F and a minimum delay of 3 minutes, the second heat stage shall energize.

On a rise in supply air temperature, the second heat stage (if applicable) shall de-energize. On a continued rise in supply air temperature, the first heat stage shall be de-energized.

Heating Operation (Staged Heaters)

On a fall in space temperature by 1°F below the heating set point (70°F, adj.), the unit shall energize its first heating stage. *The first heating stage shall modulate to meet the heating supply air set point (95°F, adj., SCR or modulating valves only).*

On a fall in space temperature by an additional 1°F and a minimum delay of 3 minutes, the second heat stage shall energize.

On a rise in space temperature, the second heat stage (if applicable) shall de-energize. On a continued rise in space temperature, the first heat stage shall be de-energized.

Humidification Operation

If the unit is not in its cooling mode, on a fall in space humidity below the humidification set point (45%RH, adj.) by 1%RH, the humidifier shall be energized. *The humidifier shall modulate to meet the space humidity set point (modulating humidifier only).*

On a rise in space humidity, the humidifier shall be de-energized.

Unoccupied Operation

If the unit utilizes the system schedule, then during unoccupied hours the fan shall be de-energized. If the space temperature falls below the unoccupied heat set point (60°F, adj.) by 1°F or rises above the unoccupied cooling set point (80°F, adj.) by 1°F, the fan shall energize and the unit shall operate as described herein. On satisfaction of unoccupied set point, the unit shall de-energize the fan.

System Alarms

Air Proving: A differential pressure switch, current sensing switch, or VFD on-board alarm closes to confirm airflow prior to the activation of other mechanical components. If the switch doesn't close after an adjustable time delay or opens during unit operation, the unit shall lock-out operation and enunciate an alarm.

Dirty Filter: An adjustable differential pressure switch shall open when the pressure drop across the filter exceeds the desired pressure drop and enunciates an alarm.

Condensate Alarm: A condensate pan switch, condensate pump overflow switch (optional), and water leak detector (optional) are connected in a NC series to detect high condensate. On a high condensate condition, the circuit will open and shut down all mechanical cooling or lock-out unit operation (optional) and enunciate an alarm.

Refrigerant pressure (DX Systems): The high refrigerant pressure (>600 psig) switch shall open on a high pressure condition, lock-out compressor operation, and enunciate an alarm. The low refrigerant pressure (<50 psig) shall open on a low pressure condition and after a time delay (90s, adjustable), shall lock-out compressor operation and enunciate an alarm.

Life Safety: A smoke detector (optional) and firestat (optional) or remote life safety system shall open a relay and break control power to the microprocessor. Unit operation shall cease. The Life Safety Alarm may optionally be routed through the controller to enunciate an alarm and signal the BMS.

High/Low Space Temperature: The unit shall enunciate an alarm if the space temperature rises above the high temperature alarm set point (90°F, adj.) or falls below the low temperature alarm set point (50°F, adj.) and the unit has been operating for at least 30 minutes.

Sensor Failure: If a sensor is reading out of range for 5 minutes, the unit shall enunciate an alarm to indicate an issue with the sensor.

Freezestat (optional): A unit mounted sensor shall sense the temperature within the unit and shall lock-out unit operation if the temperature falls below 38°F (adj.).

High CO2 Level (optional): The unit shall enunciate an alarm if the space CO2 level rises above the high CO2 alarm set point (1000 ppm, adj.) and the unit has been operating for at least 30 minutes.

Sensor Installation Schematic

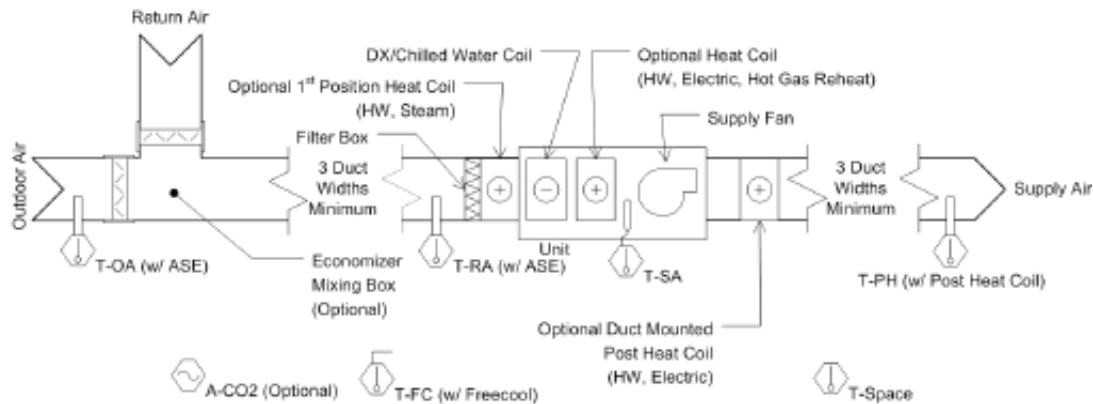

All sensors included with your unit must be installed prior to start-up or the unit will not operate. Sensors are typically either NTC type, 4-20mA, or 0-5 VDC.

Unit Display: All units are shipped with a display terminal and a 50 foot (standard) up to 200 foot cable for connection. The display terminal does not contain any sensors. It may be mounted in the space, mechanical room, or left in the electrical box. MissionCritical units ship with the display terminal cabinet-mounted. This terminal is required for unit operation.

T-Space: A space mounted dry bulb temperature sensor is provided with the unit. (This sensor is factory mounted in SpotCool and MissionCritical units). The sensor should be mounted on an interior wall in the space away from all humidity and heat sources. Mount the sensor 60" AFF unless otherwise directed by the contract documents.

T-SA: A supply air temperature is provided with the unit. This sensor is typically factory mounted at the blower inlet (units with factory mounted electric heat require a field mounted sensor).

A-CO2: If the unit is purchased with the CO2 damper control option, T-Space is supplied as a combination temperature/CO2 sensor.

T-OA: An outdoor air dry bulb temperature sensor is provided when the air-side economizer option is purchased. This sensor must be installed in the outside air duct or plenum upstream of all air mixing.

T-RA: A return air dry bulb temperature sensor is provided when the air-side economizer option is purchased. This sensor must be installed downstream of the mixing box to control the OA and RA damper positions.

T-FC: A condenser water temperature sensor is provided when the freecooling option is purchased. This sensor must be mounted on the condenser water feed to the unit, upstream of any control valves so it senses the current condenser water temperature.