

Installation Information

Heater Installation

Slip-in heaters slide through a rectangular opening in the side of the duct per Figure 8. The heater is designed for 1/4" (6.35 mm) clearance around the inside of the duct. Slip-in construction is normally preferred for ducts up to 4' (122 cm) wide, but can be furnished for any width. The heaters are held in place with sheet metal screws through the back of the terminal box into the duct. However, if the duct is over 3' (91 cm) wide, supporting rails in the bottom of the duct are recommended.

Flanged heaters are attached to matching external duct flanges per Figure 9. The heaters are secured by using either sheet metal screws or bolts and nuts through the flanges.

A special flanged construction installed with conventional HVAC slip-and-drive connectors is also available. See page 37 for details.

Either flanged or slip-in heaters can be installed in fiberglass ducts as illustrated in Figure 10. Note that a sheet metal liner must be installed into the fiberglass duct work, extending at least 6" (152 mm) beyond the heater terminal box on both sides, more if required for structural rigidity.

Field Wiring

Built-in power terminal blocks are sized for incoming copper conductors with 75°C insulation, rated to carry 125% of the heater load. However, lines may be sized to carry 100% of the heater load if a) the heater is rated at 50 KW or more, and b) the heater is controlled by a cycling device, such as a multi-staged thermostat, step controller, or SCR power controller. Terminal blocks and knockouts on such heaters will accommodate either 100% or 125% conductors. See **Table I** for field conductor and conduit sizing up to 500 MCM wiring. For higher amperages, terminal blocks are furnished for two or more parallel conductors per phase.

In general, aluminum conductors are not recommended and terminal blocks are not sized for aluminum. Consult your INDEECO representative if aluminum wire is specified for a particular job.

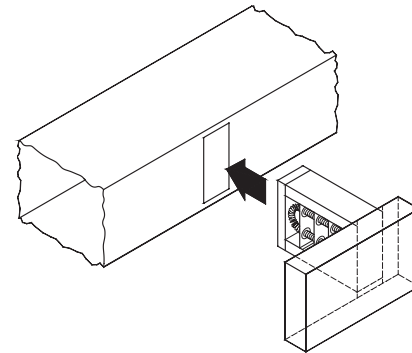

Figure 8.

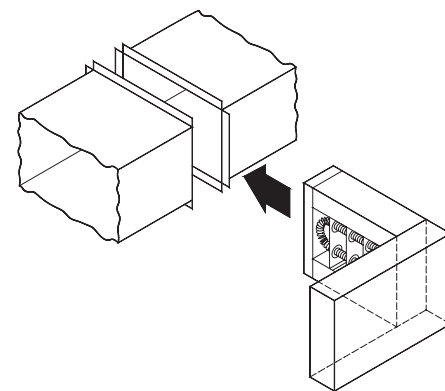

Figure 9.

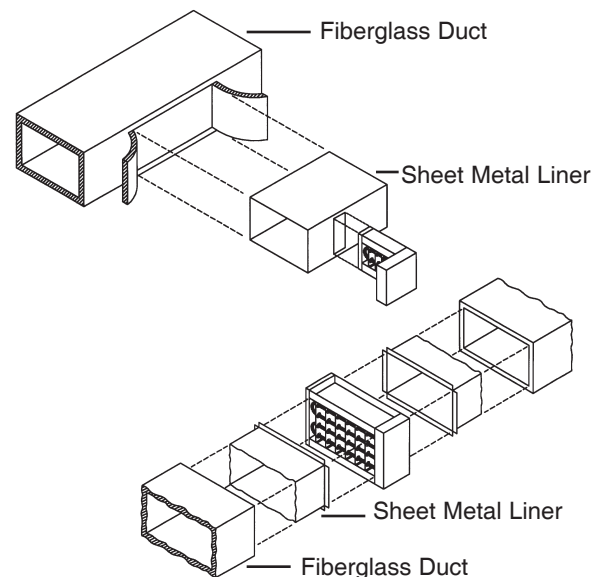

Figure 10.

Installation Information

Field control wiring should also be copper conductors with 75°C insulation. Thermostat circuits for SCR's and step controllers are NEC Class II. Many small heaters with 24 volt control circuits are also NEC Class II. When Class II wiring is permissible, it will be shown on the wiring schematic. Other control circuits are NEC Class I.

When control power is taken from the heater's load circuit lines, INDEECO provides for the overcurrent protection of all control circuits, as required by NEC or UL. When control circuit power is obtained from a separate source outside the heater, it is necessary for the installer to provide overcurrent protection for all control conductors.

Table I
Field Wiring and Conduit Sizing* for Incoming Conductors

	KW in Voltages Shown							Wire/ Size AWG or MCM	Trade Conduit Size (Inches)		Load Amps		
	Single-Phase				Three-Phase				1Ø	3Ø			
	120V	208V	240V	277V	208V	240V	480V						
Sized For 125% of Heater Load	1.4	2.4	2.8	3.3	4.3	4.9	9.9	14	1/2	1/2	12		
	1.9	3.3	3.8	4.4	5.7	6.6	13.3	12	1/2	1/2	16		
	2.8	4.9	5.7	6.6	8.6	9.9	19.9	10	1/2	3/4	24		
	4.8	10.8	9.6	11.0	14.4	16.6	33.2	8	3/4	1	40		
	6.2	10.8	12.4	14.4	18.7	21.6	43.2	6	1	1	52		
	8.1	14.1	16.3	18.8	24.4	28.2	56.5	4	1	1 1/4	68		
	9.6	16.6	19.2	22.1	28.8	33.2	66.5	3	1	1 1/4	80		
	11.0	19.1	22.0	25.4	33.1	38.2	76.4	2	1 1/4	1 1/4	92		
	12.4	21.6	24.9	28.8	37.4	43.2	86.4	1	1 1/4	1 1/2	104		
	14.4	24.9	28.8	33.2	43.2	49.8	99.7	1/0	1 1/4	1 1/2	120		
	16.8	29.1	33.6	38.7	50.4	58.1	116.3	2/0	1 1/2	2	140		
	19.2	33.2	38.4	44.3	57.6	66.5	133.0	3/0	1 1/2	2	160		
	22.0	38.2	44.1	50.9	66.2	76.4	152.9	4/0	2	2	184		
	24.4	42.4	48.9	56.5	73.4	84.8	169.6	250	2	2 1/2	204		
	27.4	47.4	54.7	63.2	82.1	94.7	189.5	300	2	2 1/2	228		
	29.8	51.6	59.5	68.7	89.3	103.0	206.1	350	2 1/2	3	248		
	32.2	55.7	64.3	74.2	96.5	111.4	222.8	400	2 1/2	3	268		
	36.5	63.2	73.0	84.2	109.5	126.3	252.7	500	2 1/2	3	304		
	Sized For 100% of Heater Load						54.0		6	1	1	65	
								70.7		4	1	1	85
							83.1		3	1	1 1/4	100	
							95.6		2	1 1/4	1 1/4	115	
						54.0	108.1		1	1 1/4	1 1/2	130	
					54.0	62.4	124.7		1/0	1 1/4	1 1/2	150	
						63.0	72.7	145.5		1 1/2	2	175	
				55.4		72.1	83.1	166.3		1 1/2	2	200	
			55.2	63.7		82.9	95.6	191.2		4/0	2	230	
		53.0	61.2	70.6		91.9	106.0	212.0		250	2	2 1/2	255
		59.2	68.4	78.9		102.6	118.4	236.9		300	2	2 1/2	285
		64.5	74.4	85.9		111.7	128.9	257.7		350	2 1/2	3	310
		69.7	80.4	92.8		120.7	139.2	278.5		400	2 1/2	3	335
		79.0	91.2	105.3		136.9	158.0	315.9		500	2 1/2	3	380

*These tabulations are based on Table 310-16 of the NEC. Not more than 3 conductors in a raceway; 75°C rated copper wire.

