

AboveAir Technologies

MC-4000N: HPOA Neutral Air Heat Pump Control Sequence and Installation Schematic

MC-4000N HPOA Neutral Air Heat Pump Control

The MC-4000N control sequence provides a constant, neutral supply air temperature for make-up air, space pressurization, or as a parallel outdoor air source. These systems are typically 100% outdoor air.

Unit Operation

Unit operation is initiated when all points are in their run positions.

System Enable: The system enable is controlled at the unit's display terminal, within the system enable menu.

Remote Stop/Start: Remote stop/start NC contacts are provided on all units and ship from the factory jumpered for continuous operation.

BMS Control: The unit is provided with an optional point that may be written by a BMS to index unit operation.

Schedule Control: The unit is provided with a local schedule that may be set to operate the unit in Occupied or Unoccupied modes based on its time clock.

Fan Control

When the unit is indexed for operation and in its occupied mode, the supply fan shall be energized after a 30 second delay (adj.) to allow for optional control damper actuation. The fan shall run continuously. After an additional 15 second delay (adj.) to allow for air proving, the unit shall operate as described herein.

Static Pressure Control (Optional): The fan is provided with a VFD and static pressure sensor. The VFD shall vary the fan speed to maintain the system static pressure set point (1.0" w.g., adj.) as the VAV boxes modulate their dampers in response to zone conditions.

CO2 Control (Optional): The fan is provided with a VFD and CO2 sensor. The VFD shall vary the fan speed to maintain the system CO2 set point (700 ppm, adj.).

Set Point Control (Optional): The fan is provided with a VFD for balancing only and will operate at a constant set point (100%/60 Hz, adj.).

System Mode

The unit shall be indexed for heating or cooling/dehumidification operation based on the mixed air condition. On a rise in mixed air temperature above the cooling operation set point (65°F, adj.), the unit shall operate based on its cooling and dew point set points to provide cooling and dehumidification. On a fall in mixed air temperature below the heating operation set point (60°F, adj.), the unit shall operate based on its heating set point (dehumidification operation is locked out).

System mode may alternately be changed via a Manual or BMS switch over.

Dehumidification Operation

On a rise in outdoor air dew point above the dew point set point (55°F, adj.) by 1°F, the unit shall enter its dehumidification mode. The unit shall energize its first compressor. *The first compressor shall energize at 100% and modulate to meet the suction pressure set point (120 psig, adj., digital scrolls only).* For dual circuit units, the second stage compressor shall be energized on a rise in outdoor air enthalpy to 55% of the unit's design capacity.

On a fall in mixed air enthalpy to less than 50% of the unit's design capacity, the second stage compressor shall be de-energized. On a continued fall in mixed air dew point below the dew point set point by 1°F, the first compressor shall be de-energized.

On a fall in mixed air dew point below the dew point set point by 1°F, the chilled water valve shall be de-energized.

Cooling Operation

On a rise in mixed air temperature by 1°F above the cooling supply air set point (75°F, adj.), the unit shall energize its first compressor stage. *The first compressor shall energize at 100% and modulate to meet the suction pressure set point (120 psig, adj., digital scrolls only).* For dual circuit units, on a rise in mixed air temperature by an additional 18°F (adj.) and a minimum delay of 3 minutes, the second compressor stage shall energize.

On a fall in mixed air temperature, the second compressor stage (if applicable) shall de-energize. On a continued fall in mixed air temperature, the first compressor stage shall be de-energized.

All compressors are subject to a minimum run time of 3 minutes and a minimum off time of 3 minutes to prevent short cycling.

Freecool (Water-Side Economizer, DX Water Cooled Only, Optional)

If the condenser water temperature is below the freecool set point (45°F, adj.) and dehumidification is not required, the unit shall energize its freecooling valve as its first stage of cooling in lieu of the first compressor stage. *The valve shall modulate to meet the supply air set point (modulating valves only).*

On a fall in mixed air temperature or on a call for dehumidification, the freecool valve shall be de-energized.

Reheat Operation

When the unit is in its cooling or dehumidification mode, reheat shall be available. The hot gas reheat coil (DX only, if applicable) is the first stage of reheat. Additional heating stages (hot water, electric) may be enabled for reheat operation.

On a fall in supply air temperature by 1°F below the cooling supply air set point, the unit shall energize its first reheat stage. *The first reheat stage shall modulate to meet the supply air set point (modulating hot gas reheat, SCR heat, or modulating hot water only).* On a fall in supply air temperature by an additional 1°F and a minimum delay of 3 minutes, the second heat stage shall energize.

On a rise in supply air temperature, the second heat stage (if applicable) shall de-energize. On a continued rise in supply air temperature, the first heat stage shall be de-energized.

Heating Operation

On a fall in supply air temperature by 1°F below the heating set point (70°F, adj.), the unit shall energize its first heating stage. *The first heating stage shall modulate to meet the space set point (SCR or modulating valves only).* On a fall in supply air temperature by an additional 1°F, and a minimum delay of 3 minutes, the second heat stage shall energize.

On a rise in supply air temperature, the second heat stage (if applicable) shall de-energize. On a continued rise in supply air temperature, the first heat stage shall be de-energized.

Heat Pump Operation

The heat pump operation stage shall supersede the other heating stages in the operational order where conditions allow.

On a fall in mixed air temperature by 1°F below the heating set point (70°F, adj.), the unit shall energize its first compressor stage. The first compressor shall energize at 100% and modulate to meet the supply air set point. For dual circuit units, on a fall in mixed air temperature by an additional 30°F, and a minimum delay of 3 minutes, the second compressor stage shall energize.

On a rise in mixed air temperature, the second compressor stage (if applicable) shall de-energize. On a continued rise in mixed air temperature, the first compressor stage shall be de-energized.

Air Cooled Only: On a call for defrost operation based on the defrost thermostat and the minimum accumulated compressor run time (30, 60, or 90 minutes, adjustable), the unit shall enter its defrost mode. The reversing valve shall energize to its cooling position and the auxiliary heat source shall energize. The unit shall remain in its defrost mode until the defrost thermostat is satisfied or for a maximum of 10 minutes. Heat pump operation is locked out below 32°F and the unit will only operate its staged heaters.

Unoccupied Operation

If the unit utilizes the system schedule, then during unoccupied hours the unit shall be de-energized.

AboveAir Technologies

MC-4000N: HPOA Neutral Air Heat Pump Control Sequence and Installation Schematic

System Alarms

Air Proving: A differential pressure switch, current sensing switch, or VFD on-board alarm closes to confirm airflow prior to the activation of other mechanical components. If the switch doesn't close after an adjustable time delay or opens during unit operation, the unit shall lock-out operation and enunciate an alarm.

Dirty Filter: An adjustable differential pressure switch shall open when the pressure drop across the filter exceeds the desired pressure drop and enunciates an alarm.

Condensate Alarm: A condensate pan switch, condensate pump overflow switch (optional), and water leak detector (optional) are connected in a NC series to detect high condensate. On a high condensate condition, the circuit will open and shut down all mechanical cooling or lock-out unit operation (optional) and enunciate an alarm.

Refrigerant pressure (DX Systems): The high refrigerant pressure (>600 psig) switch shall open on a high pressure condition, lock-out compressor operation, and enunciate an alarm. The low refrigerant pressure (<50 psig) shall open on a low pressure condition and after a time delay (90s, adjustable), shall lock-out compressor operation and enunciate an alarm.

Life Safety: A smoke detector (optional) and firestat (optional) or remote life safety system shall open a relay and break control power to the microprocessor. Unit operation shall cease. The Life Safety Alarm may optionally be routed through the controller to enunciate an alarm and signal the BMS.

High/Low Space Temperature: The unit shall enunciate an alarm if the space temperature rises above the high temperature alarm set point (90°F, adj.) or falls below the low temperature alarm set point (50°F, adj.) and the unit has been operating for at least 30 minutes.

Sensor Failure: If a sensor is reading out of range for 5 minutes, the unit shall enunciate an alarm to indicate an issue with the sensor.

Freezestat (optional): A unit mounted sensor shall sense the temperature within the unit and shall lock-out unit operation if the temperature falls below 38°F (adj.).

High CO2 Level (optional): The unit shall enunciate an alarm if the space CO2 level rises above the high CO2 alarm set point (1000 ppm, adj.) and the unit has been operating for at least 30 minutes.

Sensor Installation Schematic

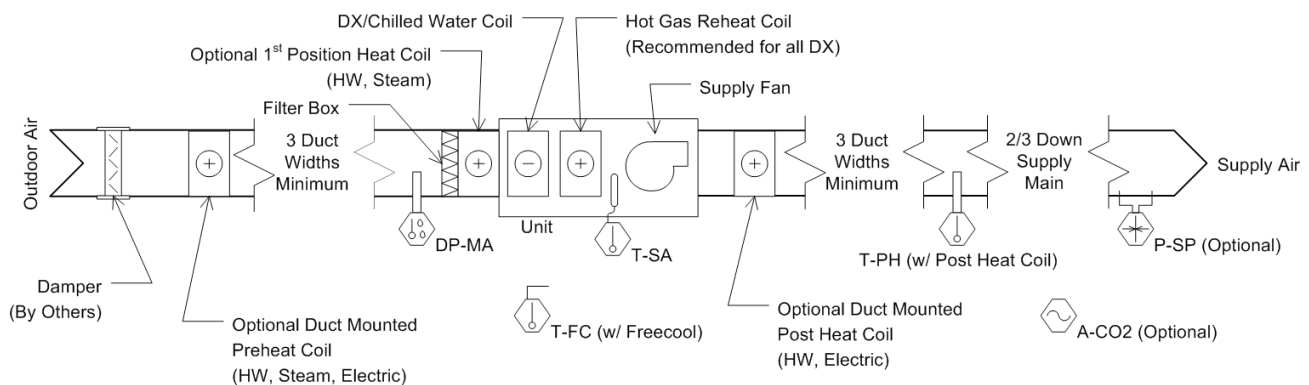

All sensors included with your unit must be installed prior to start-up or the unit will not operate. Sensors are typically either NTC type, 4-20mA, or 0-5 VDC.

Unit Display: All units are shipped with a display terminal and a 50 foot (standard) up to 200 foot cable for connection. The display terminal does not contain any sensors. It may be mounted in the space, mechanical room, or left in the electrical box. MissionCritical units ship with the display terminal cabinet-mounted. This terminal is required for unit operation.

DP-MA: A duct-mounted mixed air dew point (temperature/humidity) sensor is provided with the unit. This sensor is field installed in the mixed air stream immediately prior to the filter box. The sensor must be at least 3 duct widths downstream from any preheat coils or air mixing.

T-SA: A supply air temperature is provided with the unit. This sensor is typically factory mounted at the blower inlet (units with factory mounted electric heat require a field mounted sensor).

A-CO2: If the unit is purchased with the CO2 control option, a space or duct-mounted CO2 sensor is provided with the unit for field mounting.

T-PH: A duct-mounted post heat temperature sensor is provided with units orders with an option duct-mounted post heat stage. This sensor must be installed at least 3 duct widths downstream of the heating coil.

T-FC: A condenser water temperature sensor is provided when the freecooling option is purchased. This sensor must be mounted on the condenser water feed to the unit, upstream of any control valves so it senses the current condenser water temperature.

P-SP: A duct mounted differential pressure sensor is provided with the differential pressure VFD control option. This sensor must be mounted in the supply air duct downstream of the unit. Install 2/3 of the way down the duct main, unless otherwise directed by the contract documents.