



20/20 Interface Products

UNIVERSAL MATH MODULE

MODEL UMM

DESCRIPTION

The **UMM** is a unique multifunction micro-computer based interface that can be utilized to solve a variety of signal selection and manipulation applications. The **UMM-1** is furnished in a unique "slim-line" design housing which saves panel space and can be ordered with an optional DIN rail mounting adapter. The **UMM-2** is a snap-track mounted version whose operation is identical to the **UMM-1**. The **UMM** accepts up to four analog inputs, providing a single analog output according to the operating mode selected. This versatile product allows the user to select from the following operating modes.

USER SELECTABLE OPERATING MODES:

- **Highest or Lowest Signal Selector** – The highest or lowest of 2, 3, or 4 input signals is selected and passed instantaneously through to the output. Additional signals can be monitored by cascading multiple **UMM** boards.
- **Minimum or Peak Signal Hold Selector** – Monitoring up to three input signals, the **UMM** remembers and outputs the maximum (peak) or minimum input signal received since the last reset of the **UMM**. The peak or minimum can be reset by a remote contact.
- **Signal Averager** – The **UMM** will provide a single analog output which is the average of up to four input signals. Using a second **UMM** up to seven input signals may be averaged.
- **High and Low Limit Control** – Using the individual high and low limit adjustment pots, an upper and lower limit may be set on the output.
- **Action Reversal** – The relationship of input to output is DIP switch selectable for Direct or Reverse acting.
- **Square Root Extractor (SQ Model)**– The **UMM** will provide an output proportional to the square root of an input signal.
- **High/Low Limit Control, Action Reversal and Square Root Extractor (SQ Model)** – Any or all may be combined with either High/Low Signal Selection, or Minimum/ Peak Signal Hold or Signal Averaging.

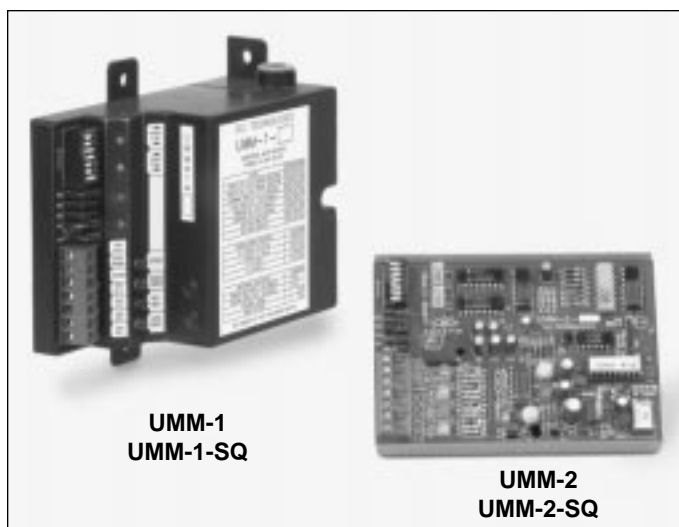

SPECIFICATIONS	
Power	24 VDC $\pm 10\%$ @ 50 mA 24 VAC $\pm 10\%$ @ 120 mA
Inputs	(4) analog: 0-5 V, 1-5 V, 0-10 V, 2-10 V, 0-20 mA, 4-20 mA
Input Impedance	mA Input: 250 Ω V Input: 70k Ω
Output	(1) analog: 0-5 V, 1-5 V, 0-10 V, 2-10 V, 0-20 mA, 4-20 mA
Output Loading	5 V range: 500 Ω min 10 V range: 1000 Ω min 20 mA range: 650 Ω max
Action	Direct or Reverse acting; DIP switch selectable
Accuracy	$\pm 1\%$ of Full Scale (except Square Root) Square Root – 1% F.S. @ 25%-100% of range 1.5% F.S. @ 10%-25% of range 2% F.S. @ 5%-10% of range 5% F.S. @ 0%-5% of range
Operating Temperature	32° to 150°F (0-70°C)
Humidity	5-95% noncondensing
Dimensions	UMM-1: 4.8"W x 3.4"H** x 2"D (12.4cm x 8.6 cm x 5.1 cm) UMM-2: 4.63"W x 3.25"H x 1"D (11.8 cm x 8.3 cm x 2.45 cm)
	**Add 1.2" (3.0 cm) for mounting tabs

HIGH AND LOW SIGNAL SELECTION

OPERATION

The **UMM** configured for this mode will accept 2, 3, or 4 analog input signals and output the signal which is either the highest or lowest of the input signals. To increase the number of input signals, **UMM's** may be cascaded by wiring the output of one **UMM** to the input of another **UMM**. Two **UMM's** wired in this fashion would allow up to 7 input signals. No calibration is required, however, high and low limits can be set on the output. Refer to the section "High and Low Limit Control" for more details.

DIPSWITCH SETTINGS AND JUMPER POSITIONS

Operating Mode	DIP Switches		
	1	2	3
Low Signal Selector	OFF	OFF	OFF
High Signal Selector	OFF	OFF	ON

Input/Output Signal Range \triangle \triangle	4	5
0-5V or 0-20 mA	OFF	OFF
1-5V or 4-20 mA	OFF	ON
0-10V	ON	OFF
2-10V	ON	ON

Action & Square Root *	6	7
Square Root Disabled (-SQ Option)	OFF	—
Square Root Enabled (-SQ Option)	ON	—
Reverse Action	—	OFF
Direct Action	—	ON

* Refer to the sections "Signal Reversal" and "Square Root Extraction" for more details.

Input Signal Type & Range	Input Jumper Position \triangle	Output Jumper Position \triangle	Jumpers
0-5V, 1-5V 0-10V, 2-10V	V	V	INPUT JUMPERS (IN1, IN2, IN3, IN4) DIS MA V OUTPUT JUMPER (OUT →)
0-20 mA 4-20 mA	MA	MA	DIS MA V
Unused "SIG IN" Terminals	DIS	—	DIS MA V

\triangle **Input Notes:** Install each input jumper for the type of signal wired to the corresponding "SIG IN" terminals. The input signal jumpers (IN1, IN2, IN3, IN4) must correspond to the signal type (V or mA) selected with DIP switches 4 and 5. All input signals wired to the "SIG IN" terminals must be of the same type and range.

Exceptions: Input signals of 1-5V and 4-20 mA may be mixed or input signals of 0-5V and 0-20 mA may be mixed. **Important: Always disable (jumper in DIS position) any input that is not to be used.**

\triangle **Output Notes:** The output signal from the "SIG OUT" terminal must be of the same type and range as the input signals. **Exceptions:** With inputs of 0-5V and/or 0-20 mA, the **UMM** may be jumpered for an output of either 0-5V or 0-20 mA. With inputs of 1-5V and/or 4-20 mA, the **UMM** may be jumpered for an output of either 1-5V or 4-20 mA.

WIRING (TYPICAL)

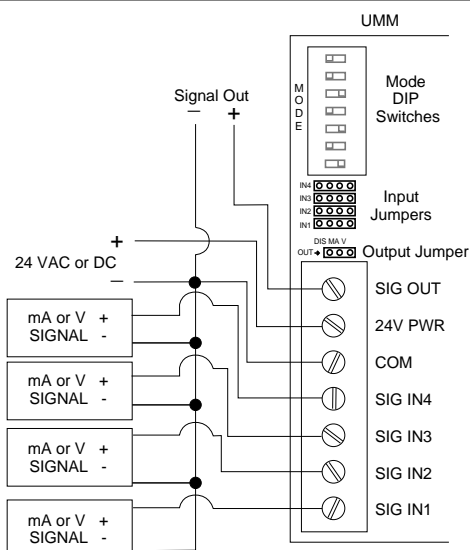

* In place of a V or mA transmitter, the signal output from another **UMM** can be wired to this input allowing selection from up to seven input signals.

LED INDICATION

- **STAT LED (Green)** - turns on when 24V is applied to **UMM**
- **HI LIM LED (Yellow)** - Turns on if output reaches the setting of the HI LIM pot. Otherwise the LED is off.
- **SEL SIG LED (Red)** - Number of blinks between pauses indicates which input signal is the currently selected signal for output.
- **LO LIM LED (Yellow)** - Turns on if output reaches the setting of the LO LIM pot. Otherwise the LED is off.

APPLICATION

This operating mode is useful for applications requiring decision making such as multipoint temperature, flow, pressure or level monitoring.

MINIMUM AND PEAK HOLD SIGNAL SELECTION

OPERATION

In the peak hold operating mode, up to 3 analog inputs are monitored. The highest peak input signal is “remembered” and the corresponding output is held until a higher input signal level occurs. In the minimum hold mode, up to 3 inputs are monitored. The lowest input signal is “remembered” and the corresponding output is held until a lower input signal level occurs. A contact closure will reset the output signal.

DIPSWITCH SETTINGS AND JUMPER POSITIONS

Operating Mode	DIP Switches		
	1	2	3
Minimum Hold Selector	OFF	ON	OFF
Peak Hold Selector	OFF	ON	ON

Input/Output Signal Range [⚠] ₁ [⚠] ₂	4	5
0-5V or 0-20 mA	OFF	OFF
1-5V or 4-20 mA	OFF	ON
0-10V	ON	OFF
2-10V	ON	ON

Action & Square Root *	6	7
Square Root Disabled (-SQ Option)	OFF	—
Square Root Enabled (-SQ Option)	ON	—
Reverse Action	—	OFF
Direct Action	—	ON

* Refer to the sections “Signal Reversal” and “Square Root Extraction” for more details.

Input Signal Type & Range	Input Jumper Position [⚠]	Output Jumper Position [⚠]	Jumpers
0-5V , 1-5V 0-10V , 2-10V	V	V	INPUT JUMPERS (IN1, IN2, IN3, IN4) DIS MA V OUTPUT JUMPER (OUT →)
0-20 mA 4-20 mA	MA	MA	DIS MA V
Unused “SIG IN” Terminals	DIS	—	DIS MA V

[⚠] **Input Notes:** Install each input jumper for the type of signal wired to the corresponding “SIG IN” terminals. The input signal jumpers (IN1, IN2, IN3) must correspond to the signal type (V or mA) selected with DIP switches 4 and 5. All input signals wired to the “SIG IN” terminals must be of the same type and range. **Exceptions:** Input signals of 1-5V and 4-20 mA may be mixed or input signals of 0-5V and 0-20 mA may be mixed. Input “SIG IN4” is used to reset the output. Jumper “IN4” should be set to “V” and the reset switch wired as shown in the wiring diagram. **Important: Always disable (jumper in DIS position) any input that is not to be used.**

[⚠] **Output Notes:** The output signal from the “SIG OUT” terminal must be of the same type and range as the input signals. **Exceptions:** With inputs of 0-5V and/or 0-20 mA, the **UMM** may be jumpered for an output of either 0-5V or 0-20 mA. With inputs of 1-5V and/or 4-20 mA, the **UMM** may be jumpered for an output of either 1-5V or 4-20 mA.

WIRING (TYPICAL)

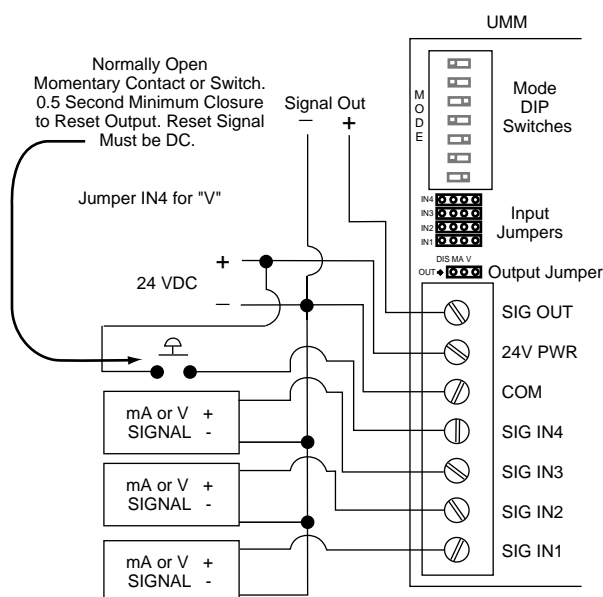

LED INDICATION

- **STAT LED (Green)** - turns on when 24V is applied to **UMM**
- **HI LIM LED (Yellow)** - Turns on if output reaches the setting of the HI LIM pot. Otherwise the LED is off.
- **SEL SIG LED (Red)** - Number of blinks between pauses indicates which input signal the current peak or minimum occurred on.
- **LO LIM LED (Yellow)** - Turns on if output reaches the setting of the LO LIM pot. Otherwise the LED is off.

APPLICATION

This operating mode is useful for monitoring peak electrical or energy demands or capturing process conditions such as flow rates.

SIGNAL AVERAGING

OPERATION

The **UMM** configured for this operating mode will accept 2, 3, or 4 analog input signals and output a signal that is the average of the input signals. To average up to 7 inputs, the “primary” **UMM** accepts four inputs and its output is wired to the first input of the “secondary” **UMM**. The output of the “secondary” **UMM** is the average of up to 7 inputs.

DIPSWITCH SETTINGS AND JUMPER POSITIONS

Operating Mode	DIP Switches		
	1	2	3
Averager (Primary Unit)	ON	OFF	OFF
Averager (Secondary Unit)	ON	OFF	ON

Input/Output Signal Range [△] ₁ [△] ₂	4	5
0-5V or 0-20 mA	OFF	OFF
1-5V or 4-20 mA	OFF	ON
0-10V	ON	OFF
2-10V	ON	ON

Action & Square Root *	6	7
Square Root Disabled (-SQ Option)	OFF	—
Square Root Enabled (-SQ Option)	ON	—
Reverse Action	—	OFF
Direct Action	—	ON

* Refer to the sections “Signal Reversal” and “Square Root Extraction” for more details.

Input Signal Type & Range	Input Jumper Position [△]	Output Jumper Position [△]	Jumpers
0-5V, 1-5V 0-10V, 2-10V	V	V	 INPUT JUMPERS (IN1, IN2, IN3, IN4) DIS MA V OUT JUMPER (OUT →)
0-20 mA 4-20 mA	MA	MA	 DIS MA V OUT JUMPER (OUT →)
Unused “SIG IN” Terminals	DIS	—	 DIS MA V

[△] **Input Notes:** Install each input jumper for the type of signal wired to the corresponding “SIG IN” terminals. The input signal jumpers (IN1, IN2, IN3, IN4) must correspond to the signal type (V or mA) selected with DIP switches 4 and 5. All input signals wired to the “SIG IN” terminals must be of the same type and range.

Exceptions: Input signals of 1-5V and 4-20 mA may be mixed or input signals of 0-5V and 0-20 mA may be mixed. **Important: Always disable (jumper in DIS position) any input that is not to be used. When using two UMM’s to average 5-7 inputs, the “primary” UMM must have all 4 of its inputs used.**

[△] **Output Notes:** The output signal from the “SIG OUT” terminal must be of the same type and range as the input signals. **Exceptions:** With inputs of 0-5V and/or 0-20 mA, the **UMM** may be jumpered for an output of either 0-5V or 0-20 mA. With inputs of 1-5V and/or 4-20 mA, the **UMM** may be jumpered for an output of either 1-5V or 4-20 mA.

WIRING (TYPICAL)

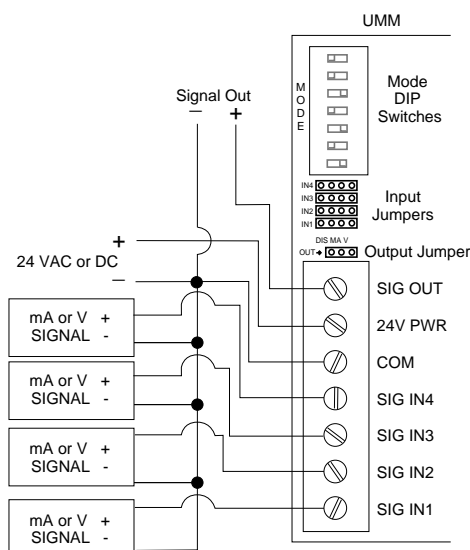

*To average up to 7 inputs, the output of the “primary” **UMM** is wired to SIG IN1 of the “secondary” **UMM**. The “primary” **UMM** must have all 4 of its inputs used.

LED INDICATION

- **STAT LED (Green)** - turns on when 24V is applied to **UMM**
- **HI LIM LED (Yellow)** - Turns on if output reaches the setting of the HI LIM pot. Otherwise the LED is off.
- **SEL SIG LED (Red)** - Cycles through all inputs that are enabled. Blinks once for INPUT 1, twice for INPUT 2, three times for INPUT 3, etc.
- **LO LIM LED (Yellow)** - Turns on if output reaches the setting of the LO LIM pot. Otherwise the LED is off.

APPLICATION

This operating mode is useful for applications requiring the average of multiple temperature, flow or pressure sensors.

SQUARE ROOT EXTRACTION

OPERATION

When the **UMM** is ordered with the optional square root function (SQ Option), it may be used as a single input square root extractor, providing an output proportional to the square root of the input signal. The square root function can also be combined with other operating modes such as High/Low Signal Selection or Peak/Minimum Hold Selection or Signal Averaging.

DIPSWITCH SETTINGS AND JUMPER POSITIONS

Operating Mode	DIP Switches			Input Signal Type & Range	Input Jumper Position	Output Jumper Position	Jumpers
	1	2	3				
Square Root Combined w/ Other Operating Modes	SET FOR REQUIRED OPERATING MODE*			0-5V , 1-5V 0-10V , 2-10V	V	V	INPUT JUMPERS (IN1, IN2, IN3, IN4) DISMA V OUTPUT JUMPER (OUT →)
Single Input Square Root Extractor	OFF	OFF	ON	0-20 mA 4-20 mA	MA	MA	DISMA V DISMA V
Input/Output Signal Range	4	5		Unused "SIG IN" Terminals	DIS	—	DISMA V DISMA V
0-5V or 0-20 mA	OFF	OFF					
1-5V or 4-20 mA	OFF	ON					
0-10V	ON	OFF					
2-10V	ON	ON					
Action & Square Root	6	7					
Square Root Disabled (-SQ Option)	OFF	—					
Square Root Enabled (-SQ Option)	ON	—					
Reverse Action	—	OFF					
Direct Action	—	ON					

△ Input Notes: When used as a single input extractor install the input jumper "IN1" for the type of signal wired to the corresponding "SIG IN1" terminal. The input signal jumper (IN1) must correspond to the signal type (V or mA) selected with DIP switches 4 and 5.

When combined with the Averaging mode, each input is square rooted before the average is computed. When combined with any other operating mode, a single input is selected before the square root is taken.

Important: Always disable (jumper in DIS position) any input that is not to be used.

△ Output Notes: The output signal from the "SIG OUT" terminal must be of the same type and range as the input signal.

Exceptions: With an input of 0-5V or 0-20 mA, the **UMM** may be jumpered for an output of either 0-5V or 0-20 mA. With an input of 1-5V or 4-20 mA, the **UMM** may be jumpered for an output of either 1-5V or 4-20 mA.

* Refer to the sections "High/Low Signal Selection", "Minimum/Peak Hold" or "Signal Averaging".

WIRING (TYPICAL)

RANGE INPUT VS OUTPUT

0 - 5V	Output = $\sqrt{\text{Input}} \times \sqrt{5}$
0 - 20 mA	Output = $\sqrt{\text{Input}} \times \sqrt{20}$
1 - 5 V	Output = $(\sqrt{\text{Input} - 1} \times \sqrt{4}) + 1$
4 - 20 mA	Output = $(\sqrt{\text{Input} - 4} \times \sqrt{16}) + 4$
0 - 10 V	Output = $\sqrt{\text{Input}} \times \sqrt{10}$
2 - 10 V	Output = $(\sqrt{\text{Input} - 2} \times \sqrt{8}) + 2$

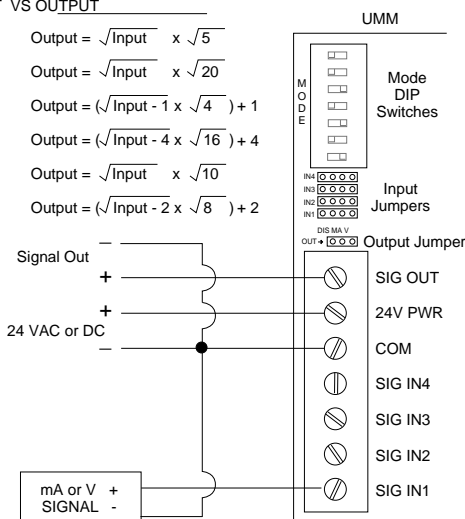

When combining the square root function with another operating mode, refer to the appropriate section for wiring details for that operating mode.

LED INDICATION

- **STAT LED (Green)** - turns on when 24V is applied to **UMM**
- **HI LIM LED (Yellow)** - Turns on if output reaches the setting of the HI LIM pot. Otherwise the LED is off.
- **SEL SIG LED (Red)** - Blinks continuously with a single signal input to terminal "SIG IN1".
- **LO LIM LED (Yellow)** - Turns on if output reaches the setting of the LO LIM pot. Otherwise the LED is off.

APPLICATION

This operating mode is useful when square root extraction is required to perform a flow calculation from a velocity pressure transmitter in air ducts or water pipes.

HIGH / LOW LIMIT CONTROL AND SIGNAL REVERSAL

OPERATION

The **UMM** may be used as a single input limit control, allowing the output to be limited to an adjustable upper and/or lower limit. When the input signal reaches the upper or lower limit setting, the output will remain at that particular limit setting. The high/low limit function can also be combined with other operating modes such as High/Low Signal Selection or Peak/Minimum Hold Selection or Signal Averaging. The output of the **UMM** can be selected to increase as the input increases (direct action) or the output can be reversed to decrease as the input increases (reverse action).

DIPSWITCH SETTINGS AND JUMPER POSITIONS				
Operating Mode	DIP Switches			
	1	2	3	
High/Low Limit w/ Other Operating Modes	SET FOR REQUIRED OPERATING MODE*			
Single Input High/Low Limit Control	OFF	OFF	ON	

Input/Output Signal Range	4	5
0-5V or 0-20 mA	OFF	OFF
1-5V or 4-20 mA	OFF	ON
0-10V	ON	OFF
2-10V	ON	ON

Action & Square Root	6	7
Square Root Disabled (-SQ Option)	OFF	—
Square Root Enabled (-SQ Option)	ON	—
Reverse Action	—	OFF
Direct Action	—	ON

Input Signal Type & Range	Input Jumper Position	Output Jumper Position	Jumpers
0-5V , 1-5V 0-10V , 2-10V	V	V	
0-20 mA 4-20 mA	MA	MA	
Unused "SIG IN" Terminals	DIS	—	

Input Notes: Install each input jumper "IN1" for the type of signal wired to the "SIG IN1" terminal. The input signal jumper (IN1) must correspond to the signal type (V or mA) selected with DIP switches 4 and 5.

Important: Always disable (jumper in DIS position) any input that is not to be used.

Output Notes: The output signal from the "SIG OUT" terminal must be of the same type and range as the input signal. **Exceptions:** With an input of 0-5V or 0-20 mA, the **UMM** may be jumpered for an output of either 0-5V or 0-20 mA. With an input of 1-5V or 4-20 mA, the **UMM** may be jumpered for an output of either 1-5V or 4-20 mA.

High/Low Limit Adjustments: To set a low limit on the output, set DIP switches 1 = ON, 2 = ON, 3 = OFF. The "LO LIM" LED will blink. With a multimeter on the "SIG OUT" and "COM" terminals, the "LO LIM" pot should be turned until the required limit setting is displayed on the meter. DIP switches 1, 2, 3 should be returned to the required operating mode settings. To set a high limit, set the DIP switches 1 = ON, 2 = ON, 3 = ON. The "HI LIM" LED will blink. The same procedure is used with the "HI LIM" pot to set the high limit. To eliminate any limit settings, the "HI LIM" pot should be turned 25 times clockwise and the "LO LIM" pot 25 times counter-clockwise.

* Refer to the sections "High/Low Signal Selection", "Minimum/Peak Hold" or "Signal Averaging".

WIRING (TYPICAL)

When combining the high/low limit functions with another operating mode, refer to the appropriate section for wiring details for that operating mode.

LED INDICATION

- **STAT LED (Green)** - turns on when 24V is applied to **UMM**
- **HI LIM LED (Yellow)** - Turns on if output reaches the setting of the HI LIM pot. Blinks when DIP switches are in the "SET HIGH LIMIT" mode. Otherwise the LED is off.
- **SEL SIG LED (Red)** - Blinks continuously with a single signal input to terminal "SIG IN1".
- **LO LIM LED (Yellow)** - Turns on if output reaches the setting of the LO LIM pot. Blinks when DIP switches are in the "SET LOW LIMIT" mode. Otherwise the LED is off.

APPLICATION

These operating modes are useful when a control signal must be limited such as for minimum positioning in damper applications or when signal reversal is required.