

#### MC-3000N HPOA Neutral Air Control

The MC-3000N control sequence provides a constant, neutral supply air temperature for make-up air, space pressurization, or as a parallel outdoor air source. These systems are typically 100% outdoor air.

#### **Unit Operation**

Unit operation is initiated when all points are in their run positions.

System Enable: The system enable is controlled at the unit's display terminal, within the system enable menu.

Remote Stop/Start: Remote stop/start NC contacts are provided on all units and ship from the factory jumpered for continuous operation.

BMS Control: The unit is provided with an optional point that may be written by a BMS to index unit operation.

Schedule Control: The unit is provided with a local schedule that may be set to operate the unit in Occupied or Unoccupied modes based on its time clock.

#### **Fan Control**

When the unit is indexed for operation and in its occupied mode, the supply fan shall be energized after a 30 second delay (adj.) to allow for optional control damper actuation. The fan shall run continuously. After an additional 15 second delay (adj.) to allow for air proving, the unit shall operate as described herein.

Static Pressure Control (Optional): The system is provided with direct-drive, backwards inclined ECM impellers and a static pressure sensor. The fan speed shall vary to maintain the system static pressure set point (1.0" w.g., adj.) as the VAV boxes modulate their dampers in response to zone conditions.

CO2 Control (Optional): The system is provided with direct-drive, backwards inclined ECM impellers and CO2 sensor. The fan speed shall vary to maintain the system CO2 set point (700 ppm, adj.).

Set Point Control (Optional): The system is provided with direct-drive, backwards inclined ECM impellers for balancing only. Fan will maintain a constant speed setting (100% output, adj.).

#### **System Mode**

The unit shall be indexed for heating or cooling/dehumidification operation based on the mixed air condition. On a rise in mixed air temperature above the cooling operation set point (65°F, adj.), the unit shall operate based on its cooling and dew point set points to provide cooling and dehumidification. On a fall in mixed air temperature below the heating operation set point (60°F, adj.), the unit shall operate based on its heating set point (dehumidification operation is locked out).

System mode may alternately be changed via a Manual or BMS switch over.

#### **Dehumidification Operation**

On a rise in outdoor air dew point above the dew point set point (55°F, adj.) by 1°F, the unit shall enter its dehumidification mode. The unit shall energize its first compressor. *The first compressor shall energize at 100% and modulate to meet the suction pressure set point (120 psig, adj., digital scrolls only).* For dual circuit units, the second stage compressor shall be energized on a rise in outdoor air enthalpy to 55% of the unit's design capacity.

On a fall in mixed air enthalpy to less than 50% of the unit's design capacity, the second stage compressor shall be de-energized. On a continued fall in mixed air dew point below the dew point set point by 1°F, the first compressor shall be de-energized.

#### **Cooling Operation**

On a rise in mixed air temperature by 1°F above the cooling supply air set point (75°F, adj.), the unit shall energize its first compressor stage. *The first compressor shall energize at 100% and modulate to meet the suction pressure set point (120 psig, adj., digital scrolls only).* For dual circuit units, on a rise in mixed air temperature by an additional 18°F (adj.) and a minimum delay of 3 minutes, the second compressor stage shall energize.

On a fall in mixed air temperature, the second compressor stage (if applicable) shall de-energize. On a continued fall in mixed air temperature, the first compressor stage shall be de-energized.

All compressors are subject to a minimum run time of 3 minutes and a minimum off time of 3 minutes to prevent short cycling.

### Reheat Operation

When the unit is in its cooling or dehumidification mode, reheat shall be available. The hot gas reheat coil (DX only, if applicable) is the first stage of reheat. Additional heating stages (hot water, electric) may be enabled for reheat operation.

On a fall in supply air temperature by 1°F below the cooling supply air set point, the unit shall energize its first reheat stage. *The first reheat stage shall modulate to meet the supply air set point (modulating hot gas reheat, SCR heat, or modulating hot water only).* On a fall in supply air temperature by an additional 1°F and a minimum delay of 3 minutes, the second heat stage shall energize.

On a rise in supply air temperature, the second heat stage (if applicable) shall de-energize. On a continued rise in supply air temperature, the first heat stage shall be de-energized.

### Heating Operation

On a fall in supply air temperature by 1°F below the heating set point (70°F, adj.), the unit shall energize its first heating stage. *The first heating stage shall modulate to meet the space set point (SCR or modulating valves only).* On a fall in supply air temperature by an additional 1°F, and a minimum delay of 3 minutes, the second heat stage shall energize.

On a rise in supply air temperature, the second heat stage (if applicable) shall de-energize. On a continued rise in supply air temperature, the first heat stage shall be de-energized.

### Head Pressure Control (Air-Cooled Units, ECM or VFD)

The condenser fan motor shall ramp up gently and operate continuously while the compressors are operating. The fan shall vary its speed to maintain the head pressure set point (325 psig, adj.), as controlled by the adjustable head pressure control PID loop.

### Head Pressure Control (Air-Cooled Units, p266)

The condenser fan motor shall ramp up gently and operate continuously while the compressors are operating. The p266 controller shall vary the fan speed to maintain the head pressure set point.

### Head Pressure Control (Water-Cooled Units)

On a call for compressor operation, the compressor start shall be delayed for 60 seconds (adj.) to allow the valve to fully open. After an initial modulation delay of 90 seconds (adj.), the valve shall modulate between its minimum and maximum operating positions based on the adjustable head

pressure control PID loop and head pressure set point (325 psig, adj.).

### Unoccupied Operation

If the unit utilizes the system schedule, then during unoccupied hours the unit shall be de-energized.

### System Alarms

*Air Proving:* A differential pressure switch or current sensing switch (optional) closes to confirm airflow prior to the activation of other mechanical components. If the switch doesn't close after an adjustable time delay or opens during unit operation, the unit shall lock-out operation and enunciate an alarm.

*Dirty Filter:* An adjustable differential pressure switch shall open when the pressure drop across the filter exceeds the desired pressure drop and enunciates an alarm.

*Condensate Alarm:* A condensate pan switch, condensate pump overflow switch (optional), and water leak detector (optional) are connected in a NC series to detect high condensate. On a high condensate condition, the circuit will open and shut down all mechanical cooling or lock-out unit operation (optional) and enunciate an alarm.

*High Refrigerant Pressure:* The high refrigerant pressure (>600 psig, auto-reset) switch shall open on a high pressure condition and shut down compressor operation. If the switch resets, the system will attempt to restart the compressor up to 3 times in 10 minutes. If the switch does not reset within 90 seconds or on 3 failed start attempts, the system shall lock-out compressor operation, and enunciate an alarm.

*Low Refrigerant Pressure:* The low refrigerant pressure (<50 psig) shall open on a low pressure condition and after a time delay (90s, adjustable), shall lock-out compressor operation and enunciate an alarm.

*Life Safety:* A smoke detector (optional) and firestat (optional) or remote life safety system shall open a relay and break control power to the microprocessor. Unit operation shall cease. The Life Safety Alarm may optionally be routed through the controller to enunciate an alarm and signal the BMS.

*Sensor Failure:* If a sensor is reading out of range for 5 minutes, the unit shall enunciate an alarm to indicate an issue with the sensor.

*High and Low Limit Alarms:* Adjustable high and low limit alarms are user-adjustable for sensor points.

*Waterflow Switch (Optional):* A differential water pressure switch is factory installed on the water lines; if the differential pressure falls below the adjustable set point, compressor operation shall be locked out.

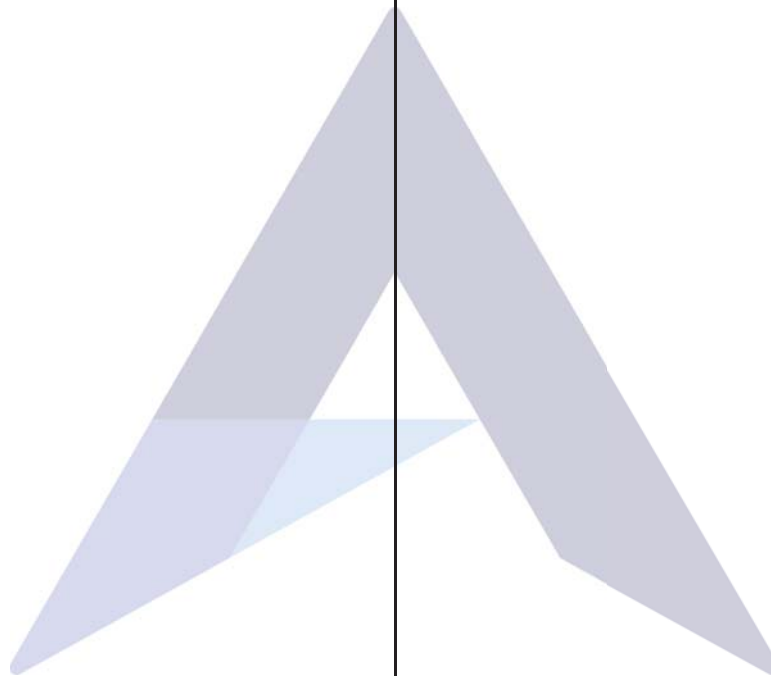

### Sensor Installation Schematic

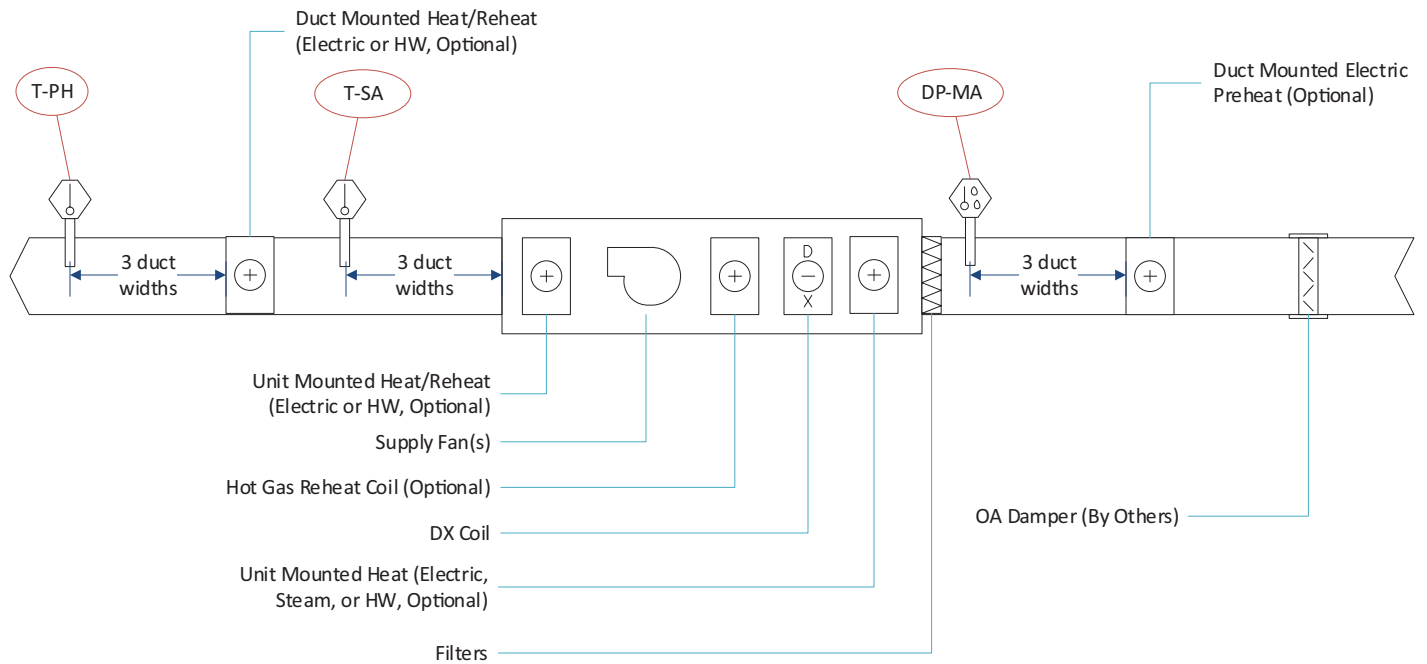

All sensors included with your unit must be installed prior to start-up or the unit will not operate. Sensors are typically either NTC type, 4-20mA, or 0-5 VDC.

#### Factory Installed Sensors

**P-HEAD1(, 2) (Not Shown):** The head pressure sensor(s) are factory installed on each circuit. Refer to piping diagrams for location detail.

**P-SUCT1 (Not Shown):** The suction pressure sensor is factory installed on the first circuit with the digital scroll compressor. Refer to piping diagrams for location detail.

#### Display

**Unit Display:** All units are shipped with a display terminal and a 50 foot (standard) up to 200 foot cable for connection. The display terminal does not contain any sensors. It may be mounted in the space, mechanical room, or left in the electrical box. MissionCritical units ship with the display terminal cabinet-mounted. This terminal is required for unit operation.

#### Field Installed Sensors

**DP-MA:** A duct-mounted mixed air dew point (temperature/humidity) sensor is provided with the unit. This sensor is field installed in the mixed air stream immediately prior to the filter box. The sensor must be at least 3 duct widths downstream from any preheat coils or air mixing.

**T-SA:** A duct-mounted supply air temperature is provided with the unit. This sensor is field mounted in the supply air stream at least 3 duct widths downstream of the unit.

**T-PH (Optional):** A duct-mounted post heat temperature sensor is provided with units orders with an option duct-mounted post heat stage. This sensor must be installed at least 3 duct widths downstream of the heating coil.

**P-SP (Optional, Not Shown):** A duct mounted differential pressure sensor is provided with the differential pressure fan speed control option. This sensor must be mounted in the supply air duct downstream of the unit. Install 2/3 of the way down the duct main, unless otherwise directed by the contract documents.

**A-CO2 (Optional, Not Shown):** If the unit is purchased with the CO2 control option option, a space or duct-mounted CO2 sensor is provided with the unit for field mounting.