

MC-7000V HPOA VAV Control

The MC-7000V control sequence is a variable air volume sequence intended to provide a constant supply air temperature and vary fan speed according to the system static pressure for units with high percentage outdoor air (>20% OA) where the ability to maintain dehumidification while resetting the supply air temperature is a concern. It serves multiple zones where each zone is provided with a VAV box with reheat.

Unit Operation

Unit operation is initiated when all points are in their run positions.

System Enable: The system enable is controlled at the unit's display terminal, within the system enable menu.

Remote Stop/Start: Remote stop/start NC contacts are provided on all units and ship from the factory jumpered for continuous operation.

BMS Control: The unit is provided with an optional point that may be written by a BMS to index unit operation.

Schedule Control: The unit is provided with a local schedule that may be set to operate the unit in Occupied or Unoccupied modes based on its time clock.

Fan Control

When the unit is indexed for operation and in its occupied mode, the supply fan shall be energized after a 30 second delay (adj.) to allow for optional control damper actuation. The fan shall run continuously. After an additional 15 second delay (adj.) to allow for air proving, the unit shall operate as described herein.

The system is provided with direct-drive, backwards inclined ECM impellers and a static pressure sensor. The fan speed shall vary to maintain the system static pressure set point (1.0" w.g., adj.) as the VAV boxes modulate their dampers in response to zone conditions.

System Mode

The unit shall be indexed for heating or cooling/dehumidification operation based on the mixed air condition. On a rise in mixed air temperature above the cooling operation set point (58°F, adj.), the unit shall operate based on its cooling and dew point set points to provide cooling and dehumidification. On a fall in mixed air temperature below the heating operation set point (53°F, adj.), the unit shall

operate based on its heating set point (dehumidification operation is locked out).

System mode may alternately be changed via a Manual or BMS switch over. The unit may also optionally reset the supply air temperature based on an optional outdoor air temperature sensor. If the reset schedule is utilized, the active supply air temperature shall reset from 55°F (adj.) at 70°F (adj.) outdoor air temperature to 65°F (adj.) at 60°F (adj.) outdoor air temperature.

Dehumidification Operation

On a rise in outdoor air dew point above the dew point set point (55°F, adj.) by 1°F, the unit shall enter its dehumidification mode. The chilled valve shall modulate 100% open.

On a fall in mixed air dew point below the dew point set point by 1°F, the valve shall modulate to its fully closed position.

Cooling Operation

On a rise in mixed air temperature by 1°F above the cooling supply air set point (75°F, adj.), the chilled water valve shall modulate to maintain the cooling supply air set point.

On a fall in mixed air temperature, the chilled water valve shall modulate to its full closed position.

Economizer (Air-Side Economizer, Optional)

If the outside air condition is below the economizer set point (69°F, adj.), the unit shall modulate the economizer dampers open. If the outdoor air temperature falls below 55°F (adj.), mechanical cooling shall be locked out and the dampers shall modulate to maintain 55°F into the unit.

On a fall in space temperature, the dampers shall return to their normal positions.

CO2 Damper Control (Optional): The economizer damper may also be set to respond to return CO2 level to provide demand control ventilation. If the space CO2 level rises above the CO2 set point (700 ppm, adj.) by 50 ppm, the damper shall open to provide the unit's maximum outdoor air supply. On a fall in return CO2 level, the damper shall return to its minimum position. If both economizer and CO2 operation are required simultaneously, the damper shall open to satisfy the larger requirement.

Reheat Operation

When the unit is in its cooling or dehumidification mode, reheat shall be available.

On a fall in supply air temperature by 1°F below the cooling supply air set point, the unit shall energize its first reheat stage. *The first reheat stage shall modulate to meet the supply air set point (SCR heat or modulating hot water only).* On a fall in supply air temperature by an additional 1°F and a minimum delay of 3 minutes, the second heat stage shall energize.

On a rise in supply air temperature, the second heat stage (if applicable) shall de-energize. On a continued rise in supply air temperature, the first heat stage shall be de-energized.

Heating Operation

On a fall in supply air temperature by 1°F below the active supply air set point, the unit shall energize its first heating stage. The first heating stage shall energize and modulate to meet the set point (SCR or modulating valves only). On a fall in supply air temperature by an additional 1°F, and a minimum delay of 3 minutes, the second heat stage shall energize.

On a rise in supply air temperature, the second heat stage (if applicable) shall de-energize. On a continued rise in supply air temperature, the first heat stage shall be de-energized.

Unoccupied Operation

If the unit utilizes the system schedule, then during unoccupied hours the unit shall be de-energized.

System Alarms

Air Proving: A differential pressure switch or current sensing switch (optional) closes to confirm airflow prior to the activation of other mechanical components. If the switch doesn't close after an adjustable time delay or opens during unit operation, the unit shall lock-out operation and enunciate an alarm.

Dirty Filter: An adjustable differential pressure switch shall open when the pressure drop across the filter exceeds the desired pressure drop and enunciates an alarm.

Condensate Alarm: A condensate pan switch, condensate pump overflow switch (optional), and water leak detector (optional) are connected in a NC series to detect high condensate. On a high condensate condition, the circuit will open and shut down all mechanical cooling or lock-out unit

operation (optional) and enunciate an alarm.

Life Safety: A smoke detector (optional) and firestat (optional) or remote life safety system shall open a relay and break control power to the microprocessor. Unit operation shall cease. The Life Safety Alarm may optionally be routed through the controller to enunciate an alarm and signal the BMS.

Sensor Failure: If a sensor is reading out of range for 5 minutes, the unit shall enunciate an alarm to indicate an issue with the sensor.

High and Low Limit Alarms: Adjustable high and low limit alarms are user-adjustable for sensor points.

Sensor Installation Schematic

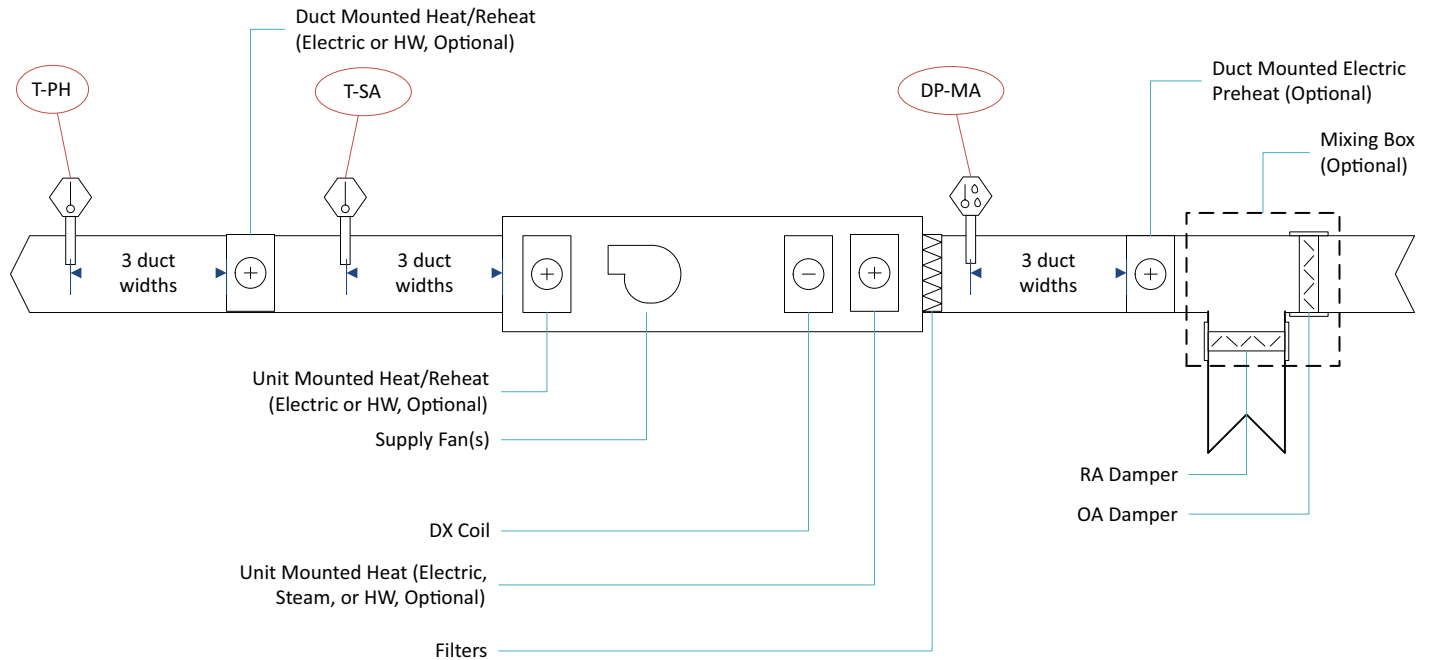

All sensors included with your unit must be installed prior to start-up or the unit will not operate. Sensors are typically either NTC type, 4-20mA, or 0-5 VDC.

Display

Unit Display: All units are shipped with a display terminal and a 50 foot (standard) up to 200 foot cable for connection. The display terminal does not contain any sensors. It may be mounted in the space, mechanical room, or left in the electrical box. MissionCritical units ship with the display terminal cabinet-mounted. This terminal is required for unit operation.

Field Installed Sensors

DP-MA: A duct-mounted mixed air dew point (temperature/humidity) sensor is provided with the unit. This sensor is field installed in the mixed air stream immediately prior to the filter box. The sensor must be at least 3 duct widths downstream from any preheat coils or air mixing.

T-SA: A duct-mounted supply air temperature is provided with the unit. This sensor is field mounted in the supply air stream at least 3 duct widths downstream of the unit.

P-SP (Not Shown): A duct mounted differential pressure sensor is provided with the unit. This sensor must be mounted in the supply air duct downstream of the unit. Install 2/3 of the way down the duct main, unless otherwise directed by the contract documents.

T-PH (Optional): A duct-mounted post heat temperature sensor is provided with units orders with an option duct-mounted post heat stage. This sensor must be installed at least 3 duct widths downstream of the heating coil.

A-CO2 (Optional, Not Shown): If the unit is purchased with the CO2 control option option, a space or duct-mounted CO2 sensor is provided with the unit for field mounting.

T-OA (Optional, Not Shown): An outdoor air dry bulb temperature sensor is provided when the air-side economizer option is purchased. This sensor must be installed in the outside air duct or plenum upstream of all air mixing.